

Battery Box Access with 3 Group 31 Batteries on a Vision Service Update #24-0217



Cable Routing Can Impede Battery Access W/3 Group 31 Batteries

Many of us may not want to admit it, but when trying to unlatch a battery tray to gain access to the batteries that seems “jammed” or even more likely that when we are trying to slide the tray back in after servicing or boosting a unit and the tray doesn’t want to push far enough in, we pick our foot up and kick at the batteries....This method is not the preferred nor a designed operation!

Upon investigating the issue, we have found that the issue is more too due with the battery cables and how they are mounted and routed than an issue with the tray slides which are often thought to be the culprit.

Figure #1 shows where a cable has dropped down behind the tray which does not allow the tray to fully slide into position for the latches to easily catch as designed.

ALL of our Service Updates can be found on the [New York Bus Sales website](#)
Or at the [New York Head Mechanic website](#)

Referencing the diagram of the battery box, tray and cable routing in FIGURE #2, we see that there is a bracket mounted to the rear of tray listed as “DETAIL A” and shown in FIGURE #3 .

As you can see, there is a 2 way “Saddle Mount” zip tie (#32) mounted to the top of the bracket which guides and holds the battery cables.

What has been found is that the zip ties are not securely holding the cables and they are allowing the cable to slip behind the tray, or they are not secured at a location where the cables fall into the side of the bracket and onto the battery tray.

To address this issue, pull the tray out to where the batteries can be serviced or replaced and then secure the zip ties of the saddle clamp.

Once you have done that, ensure that when you slide the tray back in that the cables loop onto the tray to the side of the bracket (towards rear of the unit) and not behind the tray.

**Should you find the “2 Way Saddle Mount” needs to be replaced
You can order part #00030876**

ALL of our Service Updates can be found on the [New York Bus Sales website](#)
Or at the [New York Head Mechanic website](#)



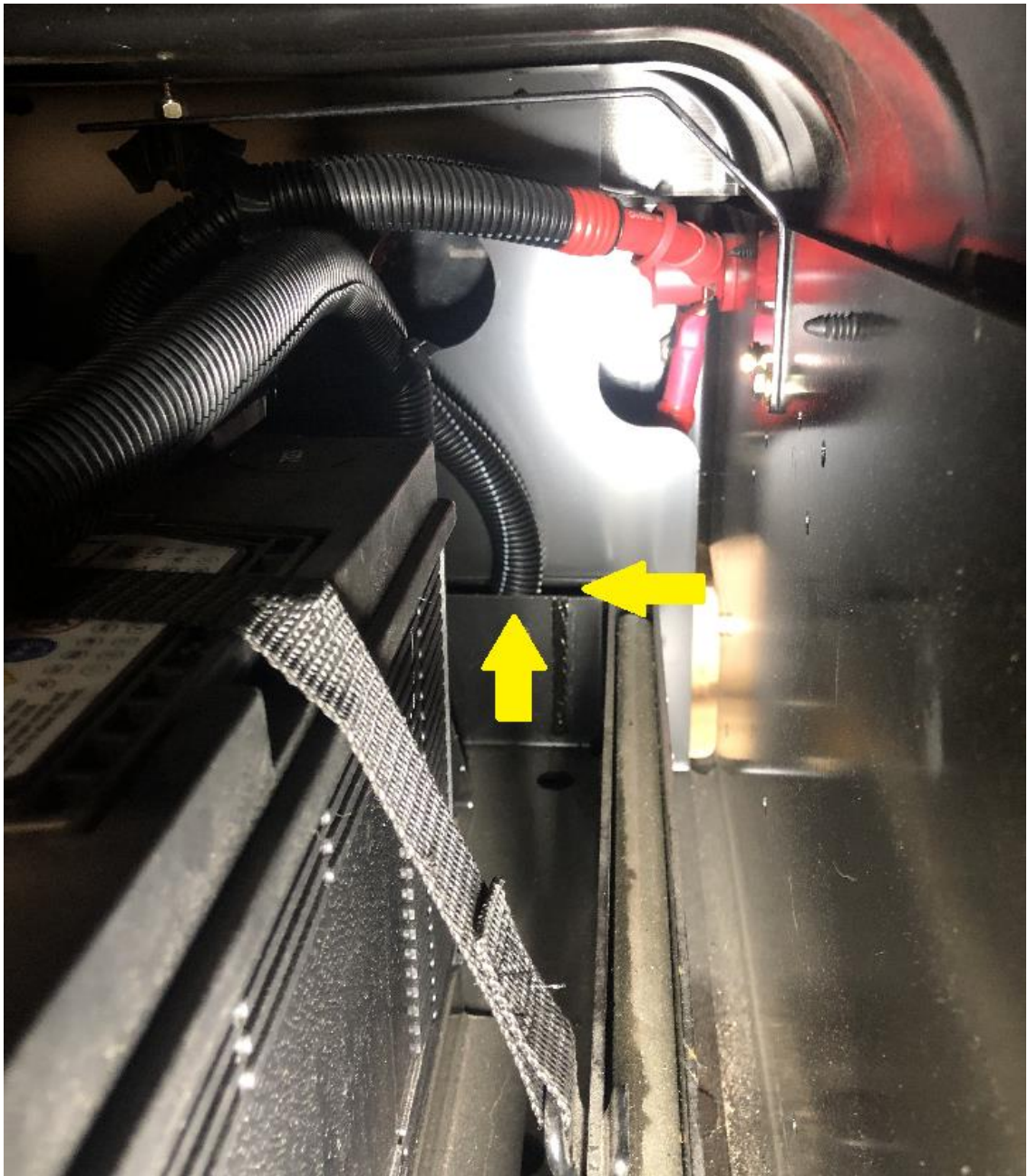

FIGURE #1

ALL of our Service Updates can be found on the [New York Bus Sales website](#)
Or at the [New York Head Mechanic website](#)

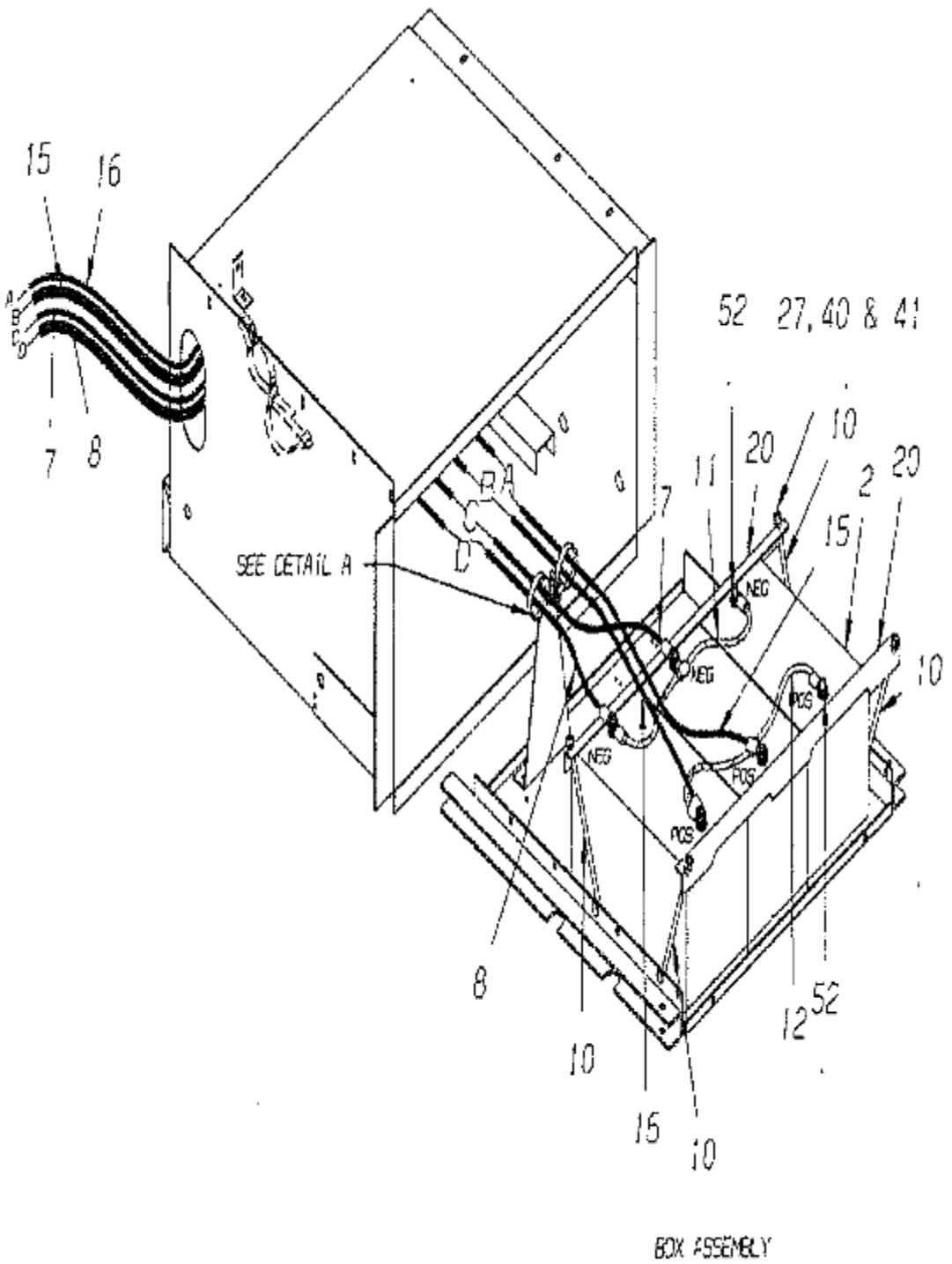

FIGURE #2

USING 3 DELCO BATTERIES

ALL of our Service Updates can be found on the [New York Bus Sales website](#)
 Or at the [New York Head Mechanic website](#)



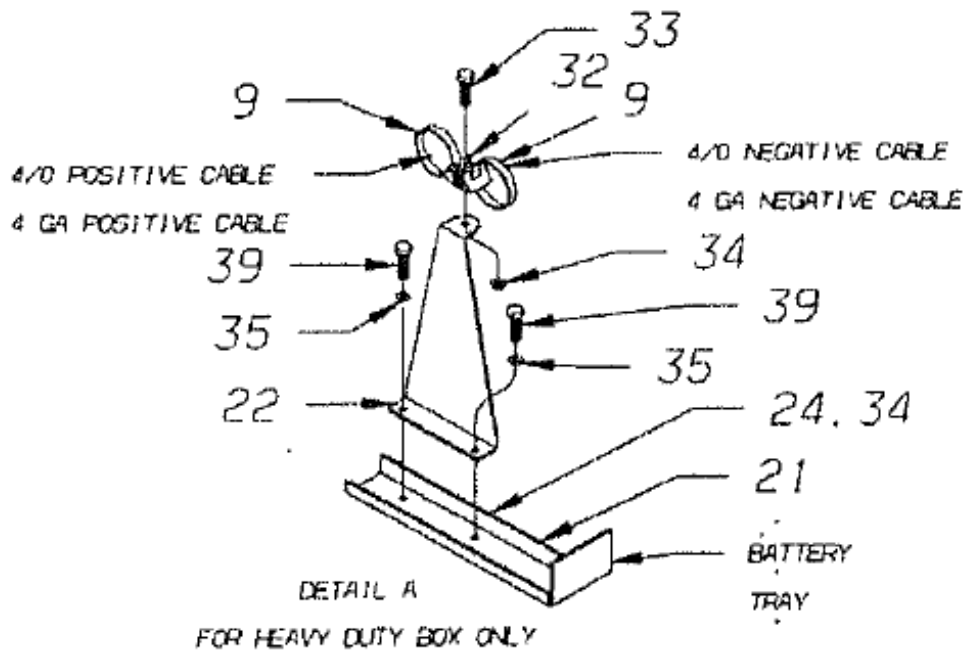

FIGURE #3

Should you find the “2 Way Saddle Mount” needs to be replaced
 You can order part #00030876

ALL of our Service Updates can be found on the [New York Bus Sales website](#)
 Or at the [New York Head Mechanic website](#)



CONTACT ANY OF OUR SERVICE LOCATIONS WITH QUESTIONS

**Director of Service
Ryan Hemund**

rhemund@newyorkbussales.com

Chittenango: 800-962-5768

Brian Lamaitis

blamaitis@newyorkbussales.com

Bob Reith

breith@newyorkbussales.com

Phil Tucker

ptucker@newyorkbussales.com

Albany: 866-867-1100

Ben Reiling

breiling@newyorkbussales.com

Batavia: 800-463-3232

Keetah Wallace

kwallace@newyorkbussales.com

ALL of our Service Updates can be found on the [New York Bus Sales website](#)
Or at the [New York Head Mechanic website](#)

