



Propane & Gasoline Grounding Straps

Parts/Service Update #24-0224



Fuel Line Grounding Straps Required

Recently we have been asked if the “Grounding Straps” (FIGURE #1) that are on the fuel metal lines of the gasoline & propane units (FIGURE #2 & #3) are required as some have been found corroded and are no longer connected.

We have contacted Blue Bird engineering to confirm these are required and there should be 2 for every metal line. The chart in FIGURE #4 lists the proper number required depending on wheelbase & suspension.

Part #10046906



FIGURE #1

ALL of our Service Updates can be found on the [New York Bus Sales website](#)
Or at the [New York Head Mechanic website](#)

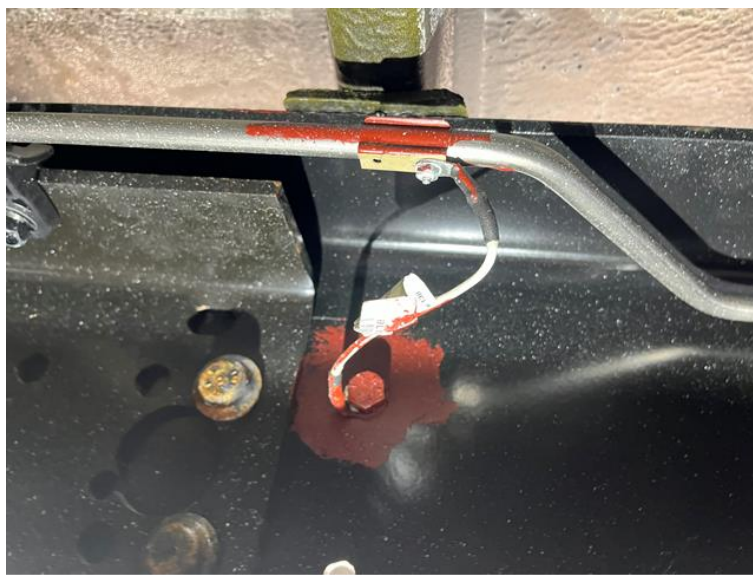
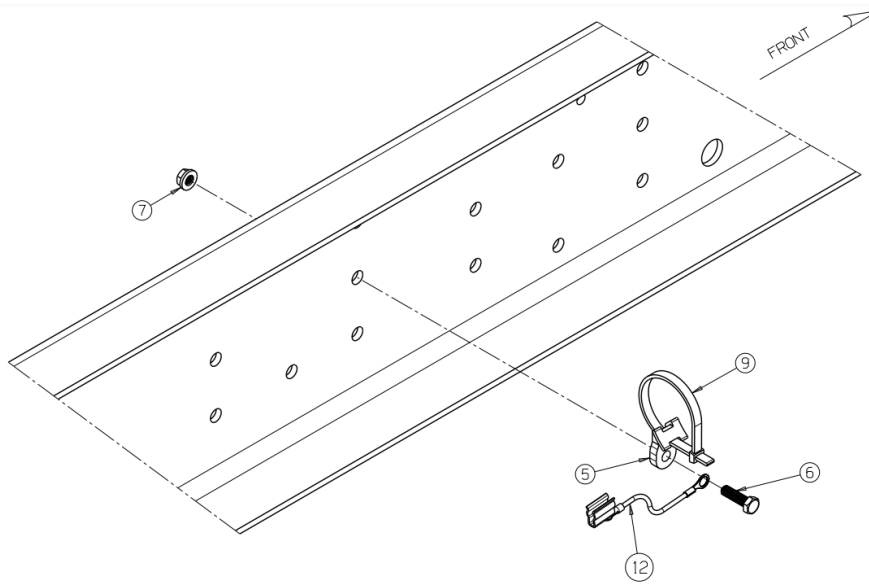

FIGURE #2



DETAIL E
SCALE: 1:3

FIGURE #3

KEY	ITEM	DESCRIPTION [Ⓔ]	Ⓔ				Ⓔ				REMARK	
			280 W/B 60 GAL FUEL TANK	280 W/B 100 GAL FUEL TANK	273 W/B 60 GAL FUEL TANK	273 W/B 100 GAL FUEL TANK	252 W/B 60 GAL FUEL TANK	252 W/B 100 GAL FUEL TANK	238 W/B 60 GAL FUEL TANK	217 W/B 60 GAL FUEL TANK		189 W/B 60 GAL FUEL TANK
12	10046906	CLIP ASSY, GROUNDING, FUEL LINE, GASOLINE	4	4	4	4	4	4	4	4	3	AIR SUSPENSION ONLY
			2	2	2	2	2	2	2	2	3	SPRING SUSPENSION ONLY

FIGURE #4

ALL of our Service Updates can be found on the [New York Bus Sales website](#)
Or at the [New York Head Mechanic website](#)



CONTACT OUR SERVICE OR PARTS DEPARTMENT WITH ANY
QUESTIONS

SERVICE

Director of Service

Ryan Hemund

rhemund@newyorkbussales.com

CELL 315-561-9121

Chittenango: 800-962-5768

Brian Lamaitis

blamaitis@newyorkbussales.com

Bob Reith

breith@newyorkbussales.com

Phil Tucker

ptucker@newyorkbussales.com

Brian Goodfellow

bgoodfellow@newyorkbussales.com

Albany: 866-867-1100

Ben Reiling

breiling@newyorkbussales.com

Batavia: 800-463-3232

Keetah Wallace

kwallace@newyorkbussales.com

PARTS

Director of Parts

Matt Woodman

mwoodman@newyorkbussales.com

CELL 315-271-9748

Chittenango: 800-962-5768

Gari McQuade

gmcquade@newyorkbussales.com

Ted Nerveldine

tneveldine@newyorkbussales.com

John Lewin

jlewin@newyorkbussales.com

Garry Maniacek

gmaniacek@newyorkbussales.com

Jim Mattner

jmattner@newyorkbussales.com

Albany: 866-867-1100

Sean Conway

sconway@newyorkbussales.com

Dan Haight

dhaight@newyorkbussales.com

Batavia: 800-463-3232

James Roeser

jroeser@newyorkbussales.com

Tyler Hartigan

thartigan@newyorkbussales.com

ALL of our Service Updates can be found on the [New York Bus Sales website](#)
Or at the [New York Head Mechanic website](#)

