

Tech Tip

FROM YOUR FRIENDS AT
NEW YORK BUS SALES!



T3FE Steering Column Boot Clamp

- Complaint –** Steering seems to have a slight “catch” in it when turning from lock to lock
- Cause –** The “boots” on the lower section of the shaft have a clamp installed which does not allow the steering shaft to turn smoothly and the boot in some cases will rip as the clamp is holding it too tight to the shaft.
- Correction –** Removing the clamp (Shown with the arrows in Figures #1 & #2) will allow the shaft to move unrestricted and without any “catching”

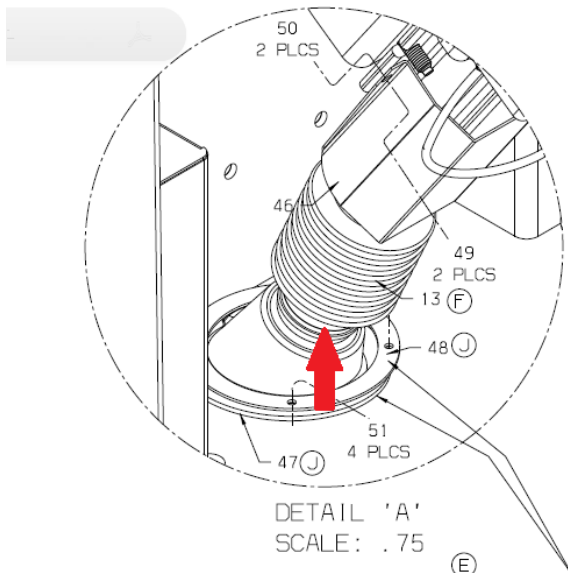

Figure #1



Figure #2



Contact Our Service Department With Any Questions

CHITTENANGO – phone 800-962-5768 or

Daryl Wallace : dwallace@newyorkbussales.com

Brian Lamaitis : blamaitis@newyorkbussales.com

ROCHESTER – phone 800-463-3232 or

Gary Chichester: gchichester@newyorkbussales.com

ALBANY – phone 866-867-1100 or

Ben Reiling: breiling@newyorkbussales.com

WARRANTY – 800-962-5768 ext 237

Morgan Jenkins: mjenkins@newyorkbussales.com

Or Your Customer Support Representative

West

Michael Panzica – mpanzica@newyorkbussales.com

Cell 716-908-3186

Central

Jeremie “JJ” Richmond –

jjrichmond@newyorkbussales.com

Cell 315-559-3999

East

Gary Bigness – gbigness@newyorkbussales.com

Cell 845-500-3707

ALL of our Tech Tips can be found on the New York Bus Sales website at

<http://www.newyorkbussales.com/pages/bulletins.cfm>

Or at the New York Head Mechanic website at

<http://www.nvhma.org/viewforum.php?f=2&start=0>