

# Tech Tip

FROM YOUR FRIENDS AT  
NEW YORK BUS SALES!



## T3FE/BBCV Coolant leak at DEF tank

**Complaint –** There is a coolant leak over the DEF tank

**Cause –** A coolant line to the DEF head is leaking due to rubbing on the bracket for the tank. Looking at the diagram in Figure #1, there are 2 coolant hoses that come through the frame at location #20 and one of the hoses come across the bracket, #10, holding the tank. After time the bracket rubs through the hose causing the leak. Figure #2 shows the hose and where it contacts the bracket on the vehicle. Figure #3 shows the hose and Figure #4 shows the bracket after rubbing on one another.

**Correction –** To correct this, if there is enough slack in the hose it should be trimmed back and if not it should be replaced. Once you have determined the proper procedure there must be “insulation” of some type put between the hose and bracket (i.e. loom, larger heater hose or rubber flooring) to protect the 2 from further rubbing. On the unit we show here, we chose rubber flooring and Figures #5 & #6 show the flooring installed.

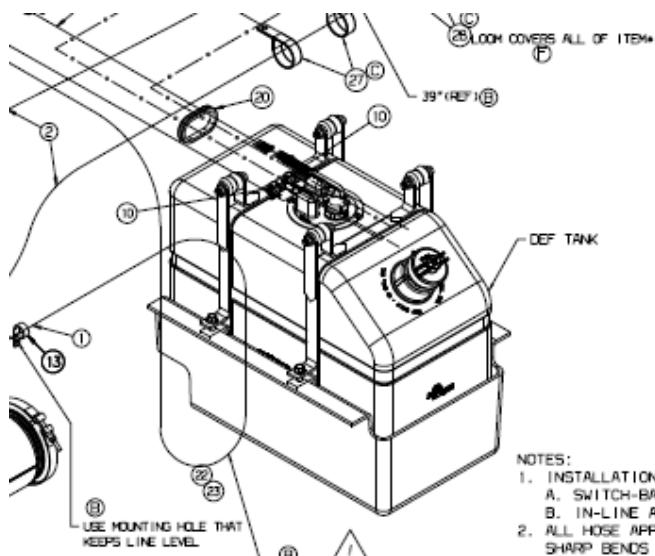

Figure #1



Figure #2



**Figure #3**



**Figure #4**

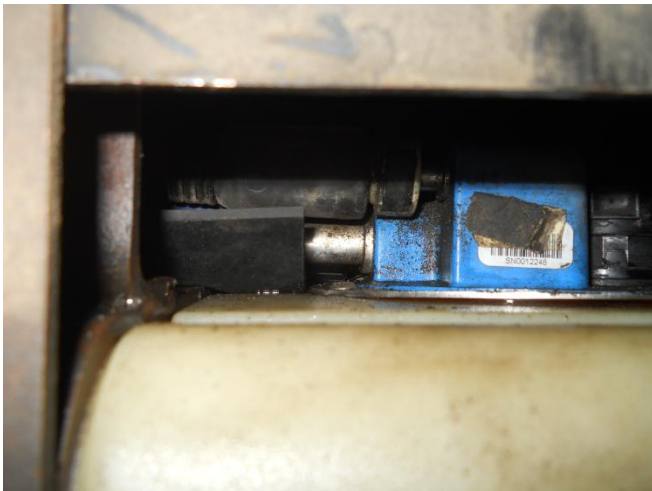

**Figure #5**



**Figure #6**



Thank You to Harlan and the guys at Dryden Central School for pointing this out to us!

ALL of our Tech Tips can be found on the New York Bus Sales website at <http://www.newyorkbussales.com/pages/bulletins.cfm>  
Or at the New York Head Mechanic website at <http://www.nyhma.org/viewforum.php?f=2&start=0>

**Contact Our Service Department With Any Questions**

**CHITTENANGO** – phone 800-962-5768 or  
Daryl Wallace : [dwallace@newyorkbussales.com](mailto:dwallace@newyorkbussales.com)  
Brian Lamaitis : [blamaitis@newyorkbussales.com](mailto:blamaitis@newyorkbussales.com)

**ROCHESTER** – phone 800-463-3232 or  
Gary Chichester: [gchichester@newyorkbussales.com](mailto:gchichester@newyorkbussales.com)

**ALBANY** – phone 866-867-1100 or  
Ben Reiling: [breiling@newyorkbussales.com](mailto:breiling@newyorkbussales.com)

**WARRANTY** – 800-962-5768 ext 237  
Morgan Jenkins: [mjenkins@newyorkbussales.com](mailto:mjenkins@newyorkbussales.com)

**Or Your Customer Support Representative**

West  
Michael Panzica – [mpanzica@newyorkbussales.com](mailto:mpanzica@newyorkbussales.com)  
Cell 716-908-3186

Central  
Jeremie “JJ” Richmond –  
[jjrichmond@newyorkbussales.com](mailto:jjrichmond@newyorkbussales.com)  
Cell 315-559-3999

East  
Gary Bigness – [gbigness@newyorkbussales.com](mailto:gbigness@newyorkbussales.com)  
Cell 845-500-3707