

Service Notice

FROM YOUR FRIENDS AT
NEW YORK BUS SALES!



AngelTrax Camera System Updates

We all know with today's electronics on vehicles, that "clean" & "constant" current is vital to operate and protect many of the electrical features.

AngelTrax has developed a "Power Conditioner" for their components and it will now be offered as a standard feature with their equipment!

Below are specifications of the power conditioner -

Contact Our Service Department With Any Questions

CHITTENANGO – phone 800-962-5768 or

Daryl Wallace : dwallace@newyorkbussales.com

Brian Lamaitis : blamaitis@newyorkbussales.com

ROCHESTER – phone 800-463-3232 or

Gary Chichester: gchichester@newyorkbussales.com

ALBANY – phone 866-867-1100 or

Ben Reiling: breiling@newyorkbussales.com

WARRANTY – 800-962-5768 ext 237

Morgan Jenkins: mjenkins@newyorkbussales.com

Or Your Customer Support Representative

West

Michael Panzica – mpanzica@newyorkbussales.com

Cell 716-908-3186

Central

Jeremie "JJ" Richmond – jjrichmond@newyorkbussales.com

Cell 315-559-3999

East

Gary Bigness – gbigness@newyorkbussales.com

Cell 845-500-3707



NEW YORK BUS SALES

**ARE YOU CURRENTLY AN
ANGELTRAX USER WHO
WOULD LIKE TO INSTALL THE
POWER CONDITIONER ON
UNITS ALREADY IN SERVICE?**

**CALL US TODAY FOR SPECIAL
PRICING!**

ALL of our Service Updates can be found on the New York Bus Sales website at

<http://www.newyorkbussales.com/pages/bulletins.cfm>

Or at the New York Head Mechanic website at

<http://www.nyhma.org/viewforum.php?f=2&start=0>

PCS2600 Power Conditioner

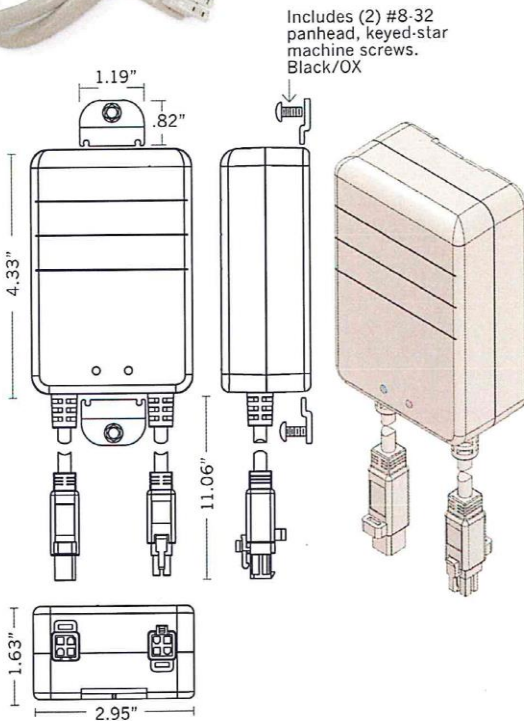
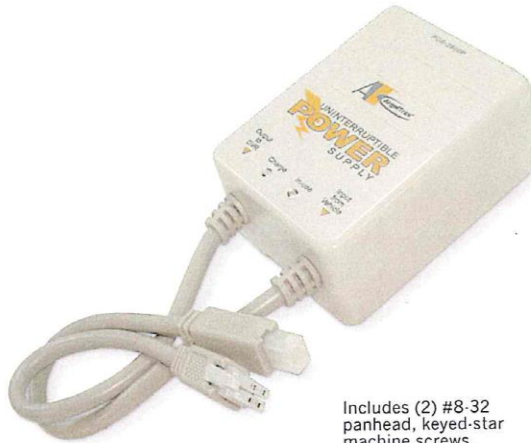

DIMENSIONS & WEIGHT

- Width: 2.95 inches
- Height: 1.63 inches
- Depth: 4.33 inches
- Cable length: 11.06 inches
- Weight: .75 pounds
- Includes connecting cable with battery pack.

ENSURE CONSTANT VOLTAGE

The stability of the vehicle's electrical system is critical to the performance and reliability of certain electronics installed on board, including all AngelTrax components. Because a standard voltage regulator used in most vehicles may not be adequate to maintain the correct voltage for specialized equipment such as video recording devices, AngelTrax engineered the PCS2600 power conditioner.

The PCS2600 separates the vehicle's electrical system from any electronics to be installed and connects directly to your AngelTrax mobile surveillance system, ensuring constant voltage and optimal performance.

NOTE: IT IS HIGHLY RECOMMENDED BY BOTH THE VEHICLE MANUFACTURERS AND ANGELTRAX THAT A "POWER CONDITIONER" BE INSTALLED ON EACH VEHICLE, SEPARATING THE VEHICLE'S ELECTRICAL SYSTEM FROM ANY ELECTRONICS TO BE INSTALLED. FAILURE TO INSTALL A "POWER CONDITIONER" MAY RESULT IN UNDESIRABLE PERFORMANCE OF THE ELECTRONICS DUE TO THE VEHICLE'S POTENTIALLY UNSTABLE ELECTRICAL SYSTEM.

SPECIAL FEATURES

- High power capacity 2600mAh/12V
- Automatic low power detection
- Wide power input range 9~32V
- Power reverse protection
- Safety charge protection

SPECIFICATIONS

- | | |
|--|------------------------------------|
| • Typical capacity | 2600mAh |
| • Maximum charge voltage | 13.05V |
| • The end discharge of voltage | 9V |
| • Charge current (max) | 1000mA |
| • Power input range | DC 9V ~ 32V |
| • Maximum continuous discharge current | 6A |
| • Life cycle | 300 (Capacity keeps more than 80%) |
| • Operating Temperature | -22°F ~ +167°F (-30°C ~ +75°C) |
| • Storage Temperature | -40°F ~ +185°F (-40°C ~ +85°C) |
| • Humidity | Under 85% RH (Non-condensing) |

