



16-0201-3

## AA/BBCV Seat Mounting @ Wall W/Simultaneous Load Seats

We recently learned of a perceived issue with respect to the mounting of seats at the wall on some units, and a question as to the number of fasteners required.

On the 39" – "3" child seat (high back w/lap belts) there are 3 bolts which mount the seat to the "ledge" of the wall – Please see Figures 1-2-3.....Figure 3 shows the 3 bolts through the seat ledge holding the seat to the ledge.



Figure one



Figure 2

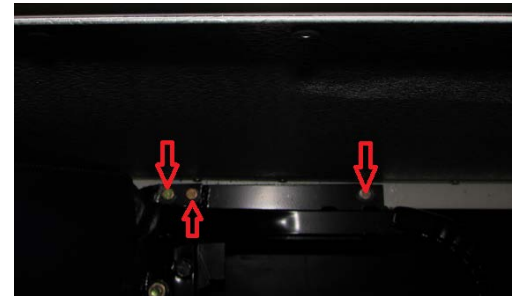

Figure3

The seat(s) in question are the 26" and 30" "2" child seat (high back w/lap belts) generally found in the left rear of a unit. Please see Figures 4-5-6. Figure 6 shows the two bolts through the seat ledge holding the seat to the ledge.



Figure 4



Figure five

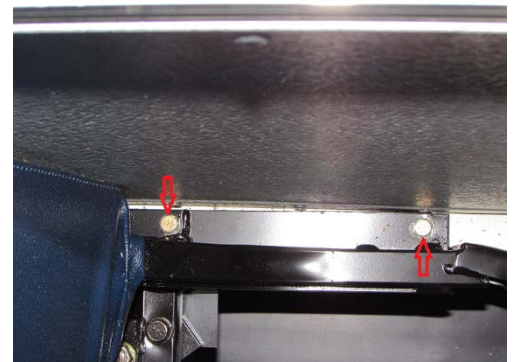

Figure 6

Blue Bird has verified this is correct and confirmed that 26" and 30" seats meet the required "pull" test with two bolts as the weight requirements are less than the 30" seats. Blue Bird drawing #D0019630 (FIGURE #7) and #D0019637 (FIGURE #8) are highlighted to show the bolt requirements for the 26" and 30" seats respectfully.

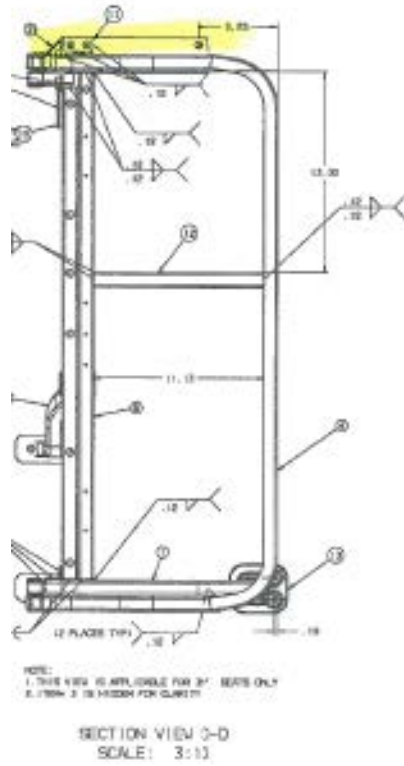

Figure 7



Figure 8

**For more information contact our nearest Service Department**

**Chittenango: 315-687-3969 or 1-800-962-5768**  
**Rochester: 585-424-3320 or 1-800-463-3232**  
**Ravena: 518-756-1111 or 1-866-867-1111**

**Daryl Wallace or Brian Lamaitis**  
**Dave Schaub**  
**Ben Reiling**

**Customer Service Representatives**

**Eastern Region Gary Bigness 845-500-3707**  
**Central Region JJ Richmond 315-559-3999**  
**Western Region Mike Panzica 716-908-3186**