

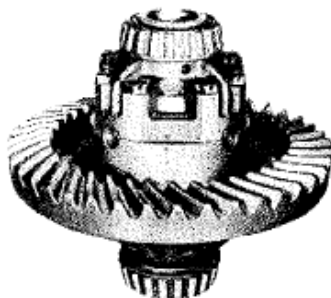

LIMITED SLIP/NO SPIN REAR AXLE NOISE

Tech Tip #16-0618



NOISE, ESPECIALLY WHEN TURNING, IS NORMAL

Recently we were made aware of concerns customers had over noise coming from the rear axles of units equipped with the option for “No Spin” rear axles. While we were aware of “normal” noise associated with this option we wanted to ensure there was nothing abnormal and researched the proper procedure required to verify operation of the axle.

Below is the information on the Dana “Detroit Locker” used in this application and as you read through the information you will see that noise is a “normal” attribute to this option. There are some things like imbalanced tire pressure in the rear tires or tire wear which will increase operational noise.

There is also a procedure for testing axles operation.

PLEASE NOTE: The testing procedure calls for the transmission to be in “park” and we have many air brake vehicles which have no “park.” You can place a bar in the rear yoke and hold it against the ground to reflect having the transmission in park.

ALL of our Service Updates can be found on the [New York Bus Sales website](#)
Or at the [New York Head Mechanic website](#)

NoSPIN



Detroit Locker®

Automatic Positive Locking Traction Differential

OWNER'S MANUAL

With warnings and precautions on back cover

Tractech has been a leading manufacturer of premium quality traction-adding differentials for over 50 years. Each step in our manufacturing process, from design to final assembly and inspection reflects the highest industry standards

This manual is intended to help provide safe and trouble free operation of NoSPIN/Detroit Locker differentials for the life of the product. We strongly recommend that all who come in contact with the products read this manual thoroughly.

GENERAL INFORMATION AND RECOMMENDATIONS

To Contact Tractech Inc.

Telephone:

(586) 759-3850 U.S.A.

FAX:

(586) 759-1645 U.S.A.

Web Site:

www.tractech.com

Office Hours:

7:30 - 4:30 (FT) Mon. - Fri.

General Assistance:

Customer Service Dept.

Technical Assistance:

Engineering Dept.

Warranty Assistance:

Customer Service Dept.

Printed Matter:

Marketing Department

Glossary

To assist the reader in understanding the language in this manual a Glossary is included.

Limited Warranty

The complete Tractech Limited Warranty appears on page 22 Owners of NoSPIN/Detroit Locker differentials are encouraged to read this warranty carefully before putting the vehicle into service.

Technical Bulletins

Tractech has published several Technical Bulletins which are helpful supplements to the information presented throughout this manual Copies are available by writing to the Marketing Dept.

Application Approval

It is essential that NoSPIN/Detroit Locker differentials be used only in applications approved by Tractech Engineering. Read page 3 carefully and follow the stated guidelines.

Model Lists

Refer only to approved Tractech model lists when ordering or specifying the products. Copies are available by writing to the Marketing Dept - Web page www.tractech.com.

Vehicle Performance

The performance of a vehicle equipped with a NoSPIN/Detroit Locker differential is somewhat different from that of a vehicle equipped with a conventional differential. Read page 4 carefully to assure proper understanding of the characteristics of the product.

Installation

Before installing NoSPIN/Detroit Locker differentials, read pages 7-11 Note: Tractech recommends that a competent driveline mechanic perform the installation in that tools of the trade are required. Note: The vehicle/axle manufacturer's instructions for installing a conventional differential must be consulted when disassembling and reassembling axle components and when making all final adjustments.

Maintenance

Refer to pages 13-16 for important information regarding proper maintenance of your NoSPIN/Detroit Locker differential. Carefully follow the recommended lubrication, service and inspection procedures.

Trouble Shooting

Information on pages 17-18 will help owners and operators of NoSPIN equipped vehicles diagnose and correct problems related to vehicle performance.

TABLE OF CONTENTS

PREFACE, GENERAL INFORMATION AND RECOMMENDATIONS	1
APPLICATION	3
VEHICLE PERFORMANCE	4
EXPLODED VIEWS OF REPRESENTATIVE ASSEMBLIES	5
OPERATION	6
INSTALLATION	7-11
TESTS FOR PROPER INSTALLATION AND OPERATION	12
MAINTENANCE	13-16
TROUBLE SHOOTING	17-18
NEW IMPROVED DETROIT LOCKER™ SPECIAL INSTRUCTIONS	19
NEW DETROIT C-LOCKER FOR C-CLIP AXLES - SPECIAL INSTRUCTIONS	20
GLOSSARY	21
LIMITED WARRANTY AND EXCLUSIONS	22
WARNING, PRECAUTIONS	23
INSTRUCTIONS TO AXLE MANUFACTURER AND CHASSIS ASSEMBLY PLANT	24

APPLICATION APPROVAL

Over the past 50 years, the NoSPIN differential has been successfully utilized by a variety of on/off road vehicle/axle manufacturers. Traditional applications are Medium/Heavy Truck, Construction, Mining, Forestry, Agricultural, Military and Specialty Vehicles.

To ensure successful application of our product, Tractech Engineering requires approval for each new vehicle/axle application. The following guidelines are examples of successful NoSPIN differential application:

Applications:

- **6x4 (tandem-drive axle) Trucks** Primary location - forward rear. Both rear axles for maximum mobility if used 75% off-road.
- **4x4 Off-Road Vehicles** Farm tractors (articulated & rigid) front axle. Also rear axle for maximum traction. (Consult Tractech Engineering.)
- **Farm Tractors** (straight frame with front-wheel-drive) -front axle only (cannot be used in rear axle with individual wheel brakes).
- **Loader** - One axle only, either front or rear.
- **Trencher** - One or both axles.
- **Front drive axles** of Light Trucks. While successful in specialty vehicles, this application must be reviewed and approved by Tractech Engineering.

It is important when considering the use of a traction device to review key vehicle parameters i.e., loading, geometry, power requirements, duty cycles (miles/hours) etc.

The following marginal applications must be reviewed with Tractech Engineering Application Approval Form No. 7003 is required. Successful field testing must be performed by the customer prior to production approval by Tractech.

Examples are:

Transit Buses- NoSPIN should not be used when operated in cities where sharp turns are required continually changing lanes, as in leaving bus stops to avoid parked vehicles.

Transit buses utilized in non city operations are an acceptable application. School busses have also proven to be another successful application for NoSPIN.

- **Yard Tractors (Spotters)**
- **Light-duty Pickup Trucks** - Equipped with fifth wheels to pull "gooseneck" trailers in pickup and delivery operations unless equipped with automatic transmission.
- **Small Fork Lift Trucks** -with short wheelbase and high turn angle capability utilized inside buildings on smooth surfaces.
- Highway Tractors - with less than 120" wheelbase (see page 4 for details).

CAUTION:

ANY INCREASE IN THE SIZE OF THE VEHICLE'S ENGINE, TIRES, WEIGHT, ETC., MAY PROHIBIT USE OF A NoSPIN DIFFERENTIAL IN A HERETOFORE APPROVED APPLICATION. ANY SUCH MODIFICATION SHOULD BE REVIEWED BY TRACTECH ENGINEERING BEFORE CONTINUING TO USE THE PRODUCT.

THE NoSPIN DIFFERENTIAL DOES NOT INCREASE THE LOAD-CARRYING CAPACITY OR PAYLOAD RATING OF THE VEHICLE OR VEHICLE COMBINATION.

• **Model Lists**

Refer only to approved Tractech model lists when ordering or specifying NoSPIN/Detroit Locker differentials. Copies are available by writing to the Marketing Dept.

*1995 Tractech Inc.

*NoSpin, Detroit Locker, Improved Detroit Locker and Detroit C-Locker are registered Trademarks of Tractech Inc.

VEHICLE PERFORMANCE

The performance of a vehicle equipped with a NoSPIN/Detroit Locker differential is somewhat different from that of a vehicle equipped with a conventional differential. For example:

When turning a corner, the sound of component disengagement and re-engagement may be audible, and the transfer of driving torque from both wheels to one wheel may be noticeable.

When going from drive (acceleration) to coast (deceleration) in a turn, a "metallic" sound may be heard as torque flow is reversed (inside wheel engaged during acceleration; outside wheel engaged during deceleration).

These characteristics are normal because of backlash designed into the NoSPIN differential, which is of a fixed amount (1 to 2 inches of rotation at the tire tread).

Backlash or slack between the driving and driven clutch teeth is an inherent part of the NoSPIN and necessary to permit automatic operation when driving in forward and reverse. The total backlash in the driveline is increased by the amount of the reduction between the ring gear and pinion. If the ring gear-pinion ratio is 5 to 1, the total backlash in the driveline with the NoSPIN would be about 30°. This in turn is increased by clearances between planetary gear, sliding splines and the ring and pinion gear. We feel that the total driveline slack can amount to as much as 1/4th turn of the driveline without being abnormal but if it exceeds 1/4 turn, other parts in the drivetrain could be checked. Further clarification of operational and performance characteristics is available through Technical Bulletin No. 81-1044. A copy is available by writing to our Marketing Dept.

Anything that improperly causes a difference in individual wheel speeds, such as mismatched tire diameters due to differences in tire wear or tire pressure, or unbalanced loading of the vehicle (especially cargo vehicles, or vehicles operated on a side slope) can cause the NoSPIN differential to deliver power to only one side of the vehicle and thus cause steering problems.

The diameter of the tires can be adjusted by varying the air pressure of the tires.
Match the distance from the top of each tire rim to the pavement.

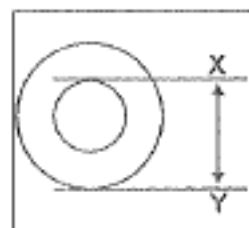

When negotiating a turn (outside wheel disengaged), the inside wheel under conditions of poor traction may receive excessive torque, which could cause it to break traction momentarily until its speed is equal to the outside wheel. This will result in re-engagement of the outside wheel thus allowing both wheels to be driven. This condition is most noticeable with lightly loaded axles.

Certain vehicles equipped with NoSPIN differentials, such as short wheelbase trucks (e.g., under 120" wheelbase) and four wheel drive trucks with a NoSPIN differential in the front steering axle, can experience "understeer" when negotiating a turn under power. Releasing the accelerator will reduce the torque and improve steering.

Use extreme caution when accelerating or decelerating on slippery or unstable surfaces. Vehicles/axles equipped with traction differentials are inherently more sensitive to side-slip than vehicles equipped with conventional differentials. Stability can be retained if side-slip occurs by decelerating (Letting off the accelerator) CAUTION: DO NOT APPLY THE BRAKE. TO DO SO MAY RESULT IN LOSS OF VEHICLE CONTROL.

Braking capacity is reduced when a NoSPIN differential equipped vehicle makes a turn while coasting downhill in that the inside wheel is then disconnected from the driveline. Operating in low gear will allow the engine to act as a retarder and will improve braking capacity.

If the vehicle is stationary on a dry surface, easier steering can be achieved by moving the vehicle slightly in either forward or reverse. (Assure that proper steering pressure is maintained.)

NOTE:

If placing limited-slip differentials in Rockwell, Eaton or Dana axles with NoSPIN differentials, also replace the differential case halves with the axle manufacturer's standard differential case halves. NoSPIN differentials are designed to fit standard differential case halves. NoSPIN differentials will not fit properly into limited-slip differential case halves.

THE NoSPIN DIFFERENTIAL DOES NOT INCREASE THE LOAD-CARRYING CAPACITY OR PAYLOAD RATING OF THE VEHICLE OR VEHICLE COMBINATION.

The following exploded views of NoSPIN differentials (there are five "styles") illustrate the various components that make up the complete assembly. Certain components differ slightly in appearance between style, but their function - and the function of each of the five style NoSPIN differentials - is the same

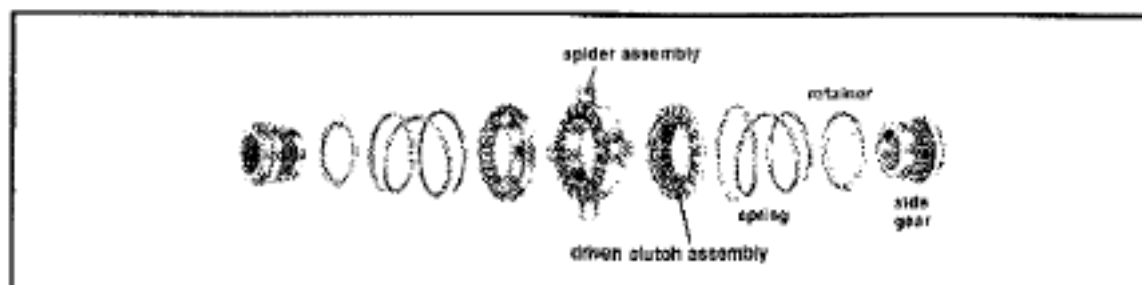

NoSPIN differential with spider assembly and external springs and retainers; fits support case in vehicle.

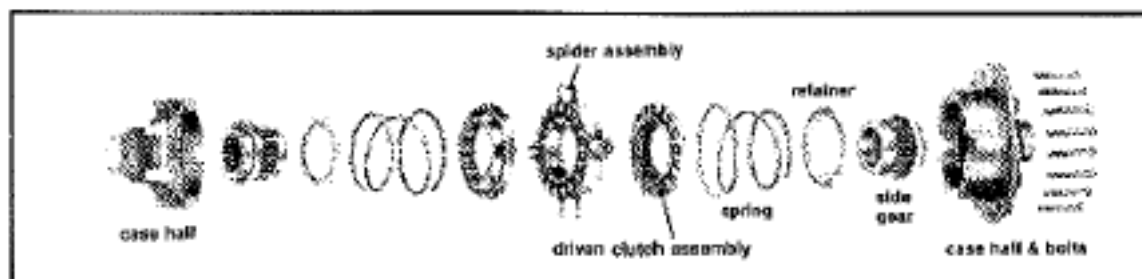

NoSPIN differential with spider assembly and external springs and retainers; supplied with support case.



NoSPIN differential with spider assembly and internal springs and retainers; fits support case in vehicle.

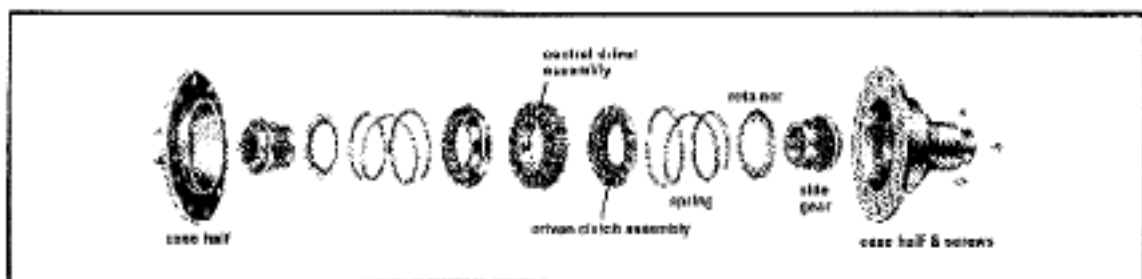

Assembly style not shown:

New IMPROVED Detroit Locker. See page 19

Models with central driver, external springs and retainers, without support case.

Copies of style not shown are available by writing to the Marketing Dept.

The NoSPIN differential powers both wheels. Yet freely permits wheel speed differentiation when required.

Prime functions

1. Assures 100% of the available torque and increases drawbar pull.
2. Prevents wheel spin and power loss when one wheel loses traction.
3. Compensates for differences in wheel travel when turning or operating on uneven surfaces.

The drive axle illustrated below (Fig. 1) is equipped with a NoSPIN differential. Note that there are no spider gears, but rather two drive members, called driven clutch assemblies. They mate with a spider assembly which is driven by the ring gear through the differential support case.

As long as the vehicle is operated in a straight forward or reverse direction over a smooth surface, the driven clutch assemblies remain locked to the spider assembly.

The NoSPIN differential allows the vehicle to perform as if the axle half-shafts had been welded - the axle is completely locked. This means both wheels turn at the same speed. If one wheel loses traction or leaves the ground, the opposite wheel, which still has traction, continues to drive the vehicle until traction is regained by both wheels. There can be no one wheel spinout. (Fig. 2)

When the vehicle turns a corner, or when one wheel passes over an obstruction, the outside wheel, or the wheel passing over the obstruction, must travel a greater distance and therefore faster than the other wheel. When this occurs, the NoSPIN differential automatically allows for the necessary difference in wheel speed.

During a turn (Fig. 1), the inside driven clutch remains completely engaged with the spider and continues to drive the vehicle. The outside driven clutch automatically disengages from the spider, allowing the outer wheel to turn freely in the turn. When the vehicle completes the turn, the outside driven clutch automatically reengages the spider, as both wheels again travel at the same speed.

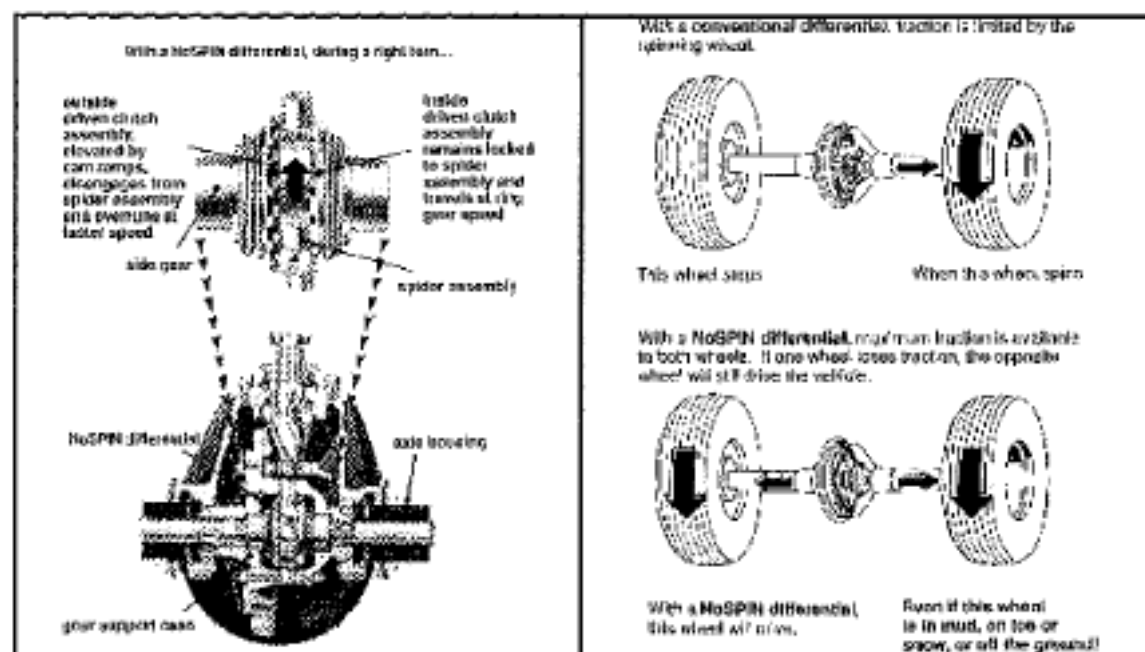

Refer only to an approved Tractech model list when ordering or specifying the product. Copies are available by writing to the Marketing Department.

It is essential that NoSPIN/Detroit Locker differentials be used only in applications approved by Tractech Engineering. Read pages 3-4 carefully and follow the approved guidelines.

The installation procedure presented on pages 7-11 applies to all NoSPIN differentials (except 'R' Model NoSPIN Differentials). However, the procedure will differ slightly depending upon the specific vehicle. Therefore it is essential to consult the vehicle/axle manufacturer's instructions for installing a differential.

Most NoSPIN/Detroit Locker differentials are designed to fit directly into the standard differential support case in the vehicle. Where it is not possible to fit the standard support case manufactured by the vehicle/axle maker, the NoSPIN differential is supplied with a case manufactured by Tractech. Therefore, two sets of installation instructions are provided.

NoSPIN differentials are easily installed in the field. However, it is recommended that a competent driveline mechanic do the work in that tools of the trade are required.

The NoSPIN differential is designed to fit the components in the axle. No machining is required. The procedure is the same as it is for installing the original differential. A competent mechanic can install the NoSPIN in the same time required to replace the original differential. Caution: It is recommended every safety precaution be practiced while performing the work when disassembling and reassembling axle components and when making all final adjustments.

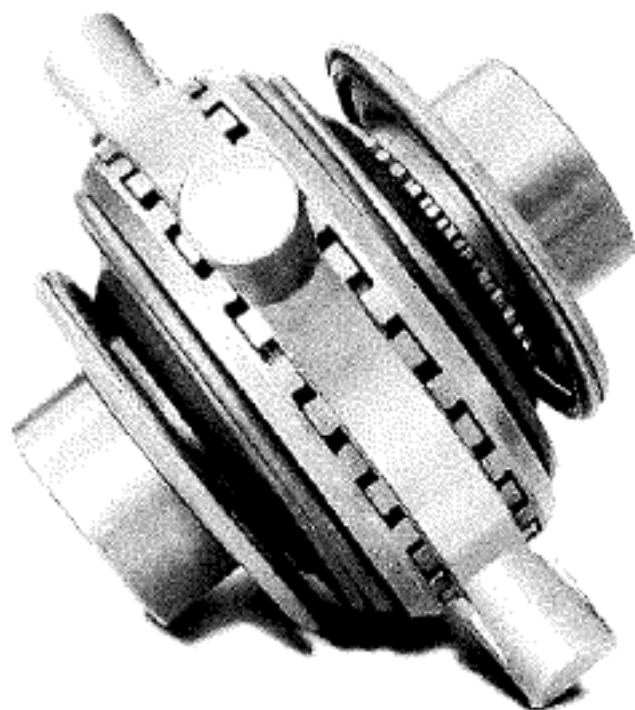

**Installation Instructions:
NoSPIN/Detroit Locker Differentials Supplied Without a Support Case**

Step 7

Position the remaining differential case half over the NoSPIN differential.

NOTE:

Be sure both case halves are in the original (marked) position.

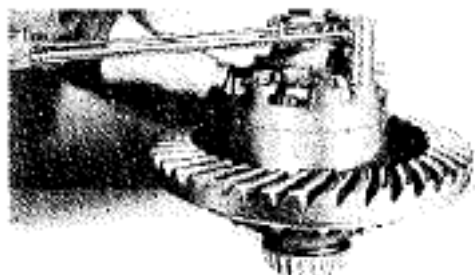
**Step 8**

Using a torque wrench, tighten the differential case bolts securely to the torque limit recommended by the vehicle/axle manufacturer's instructions. Assure that there is a tight fit between the spider trunnions and the case.

NOTE:

A loose fit between the spider and the case can cause malfunction of the NoSPIN Differential.

Step 9

Remove the retainer bolt, nut and washers. (Retain for future service work.)

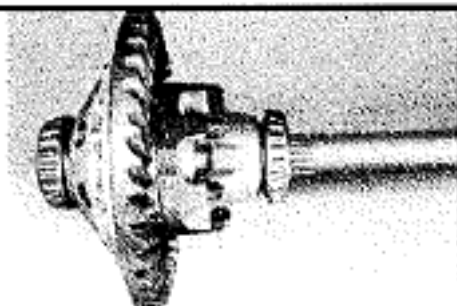
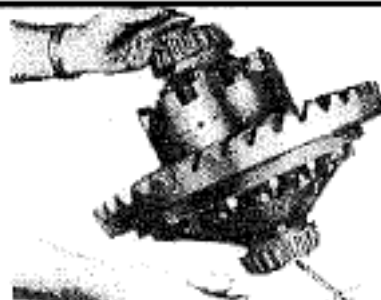
**Step 10**

Insert axle shafts into splined side gears of the NoSPIN differential. The shafts should slide in freely but fit correctly.

Step 11

Install the differential and ring gear assembly in the axle housing. Complete the reassembly of associated components as recommended by the vehicle/axle manufacturer's instructions.

NOTE:

Contamination, such as metal particles in the differential case, can cause the differential to malfunction. Be sure the axle housing is clean before proceeding.

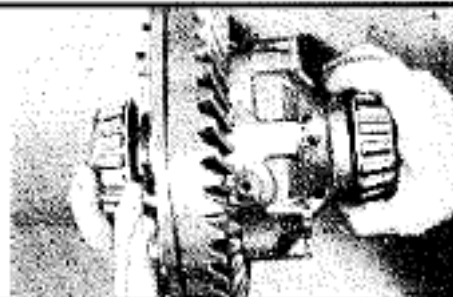
**Step 12**

Refill the axle housing with lubricant recommended for differentials by the vehicle/axle manufacturer.

Step 13

Apply Caution Label to instrument panel in full view of operator or mechanic. If you did not receive this label, contact Tractech's Marketing Department.

Step 14

Follow the test procedures outlined on page 12 to assure proper installation and operation of the NoSPIN differential.

NOTE:

If the NoSpin differential is disassembled, be sure to reassemble both clutch assemblies to the spider assembly with the 'slot' in each holdout ring over the long tooth of the spider.



Disassembly: (Steps 1-5)

Step 1

Refer to the vehicle/axle manufacturer's recommendations for removing the differential assembly from the axle. Ensure that all safety precautions are implemented.

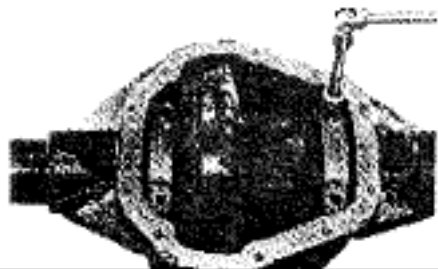

Step 2 Following the procedure recommended by the vehicle or axle manufacturer, remove the ring gear and differential case assembly from the axle carrier.

CAUTION:

Do not use heat to disassemble drive axles. To do so can destroy heat treat properties, weaken or distort axle components or result in a mishap which can cause injury, even death.

Step 3

Using the proper bearing puller, carefully remove the bearing cone assemblies from the original differential case. *Replace bearings if worn or damaged during disassembly.* If shims are used behind the bearing cone assemblies, record the amount of shim pack under each bearing.

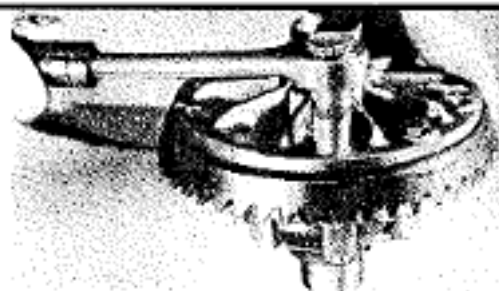

Step 4

Remove the ring gear from the original differential case. Record the dimension from the ring gear flange face to the nearest bearing shoulder. Record the dimension from one bearing face to the other.

Step 5

Store the original differential and case for use if the NoSPIN differential requires service. Protect parts from damage or corrosion.





Step 6

Wash the ring gear, ring gear bolts, shims, and bearing races using a nonflammable, non-toxic cleaning solvent that will not etch, scratch or oxidize the parts. Rinse in clean solvent and dry. Inspect for damage, wear or corrosion. Replace if necessary with identical axle/vehicle manufacturer approved components.

Step 7

Clean and examine the splined ends of the axle shafts. Remove any roughness or burrs with a file or stone. Examine the shafts for straightness, cracks or other damage. Replace if necessary. Make sure splines on axle match splines on NoSPIN differential side gear.

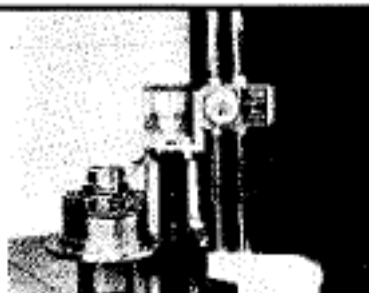

Step 8

If shims are used behind the bearing cone assemblies, measure the NoSPIN differential support case from the ring gear flange face to the nearest bearing shoulder and from one bearing shoulder to the other. Adjust the shim pack at each bearing journal to the dimension recorded previously from the original differential case.

Step 9

Using a torque wrench, bolt the ring gear to the NoSPIN differential and case assembly. Tighten the ring gear bolts securely to the torque limit recommended by the vehicle/axle manufacturer.

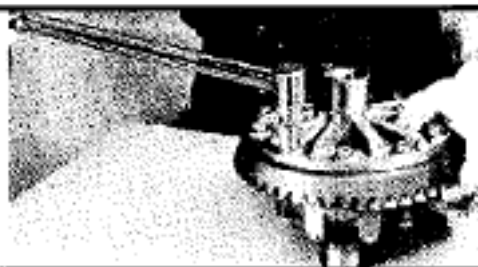

Step 10

Using an Arbor press with an arbor of the correct size, press the bearing cone and roller assemblies onto the hubs of the NoSPIN differential support case until they are properly and squarely seated.

Step 11

Install the differential and ring gear assembly in the axle housing. Complete the reassembly of associated components as recommended by the vehicle/axle manufacturer's instructions. Note: Contamination, such as metal particles in the differential case, can cause the differential to malfunction. Be sure the axle housing is clean before Proceeding.

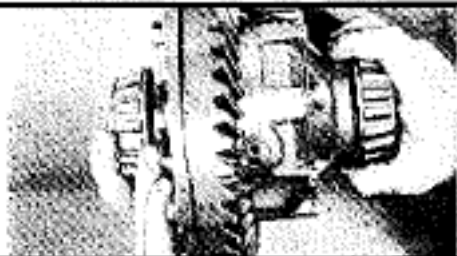

Step 12

Refill the axle housing with lubricant recommended for differentials by the vehicle/axle manufacturer.

Step 13

Apply Caution Label to instrument panel in full view of operator or mechanic. If you did not receive this label, contact Tractech's

Step 14

Follow the test procedures outlined on page 12 to assure proper installation and operation of the NoSPIN differential.

NOTE: If the NoSPIN differential is disassembled, be sure to reassemble both clutch assemblies to the spider assembly with the 'slot' in each holdout ring over the long tooth of the spider.

INSTALLATION TEST

Step 1

With the engine turned off, raise NoSPIN equipped driving axle(s) until all wheels are out of contact with any surface. Place the transmission in gear or park so that the driveshaft is locked and does not rotate.

NOTE: Test for forward disengagement:

Step 2

With two people, rotate both wheels rearward, as far as possible to lock both wheels.

Step 3

With the left wheel securely held in the rearward direction, rotate the right wheel slowly forward. A faint indexing or clicking sound should be heard as the NoSPIN disengages on the right side.

Step 4

With the right wheel slowly rotating forward, the left wheel should be rotated slightly forward. This will lock both wheels.

Step 5

Again, rotate both wheels rearward, as far as possible to lock both wheels.

Step 6

With the right wheel securely held in the rearward direction, rotate the left wheel slowly forward. A faint indexing or clicking sound should be heard as the NoSPIN is disengaged on the left side.

Step 7

With the left wheel slowly rotating forward, the right wheel should be rotated slightly forward. This will lock both wheels.

Repeat steps 2-7 except, test for reverse disengagement. If the above steps are completed successfully and rotating wheels disengage easily by hand, rotate freely and evenly, lock both wheels when required, and produce a faint indexing or clicking sound, then the NoSPIN is properly installed and is functioning correctly.

IF EITHER WHEEL DOES NOT ROTATE FREELY IN EITHER DIRECTION or does not lock both wheels as required, recheck the installation of the NoSPIN in the axle. Also check hand and foot brakes for possible drag caused by improper adjustment. Be sure that all thrust washers have been removed from the standard differential support case.

To check normal NoSPIN operation, drive the vehicle on a flat surface with good traction, in a right or left circle in forward and reverse to be sure that the outside wheel is free to overrun (i.e. that the outside tire does not scuff). A clicking or indexing sound may be heard. The sound of gear re-engagement may also be heard upon completion of the turn. This is normal.

OPERATION TEST

Check to see that both wheels of each NoSPIN differential equipped axle are driving. Make this test under load, so that engine torque is applied through the NoSPIN differential with the wheels on the ground. One way to achieve this load is to drive up against a solid obstruction (on loose dirt or gravel, if possible) and attempt to spin both wheels together. Perform this test in forward and reverse. (Exercise caution when performing this test to avoid damage to vehicle or obstruction.)

CAUTION: DO NOT OPERATE THE VEHICLE IF BOTH WHEELS OF A NoSPIN/DETROIT LOCKER EQUIPPED AXLE ARE NOT DRIVING. POWER TO ONLY ONE WHEEL CAN CAUSE SERIOUS STEERING PROBLEMS AND LOSS OF VEHICLE CONTROL AND RESULT IN A MISHAP WHICH CAN CAUSE PROPERTY DAMAGE, INJURY, EVEN DEATH.

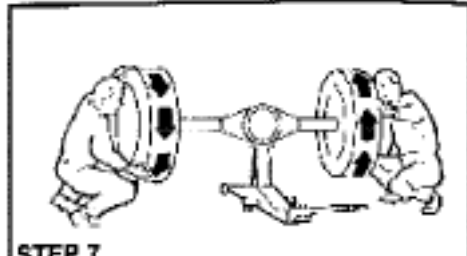
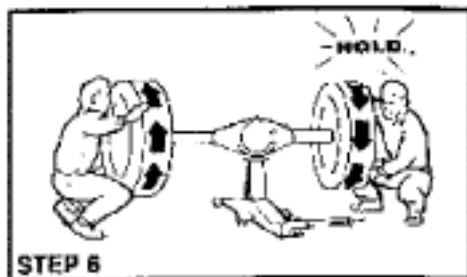
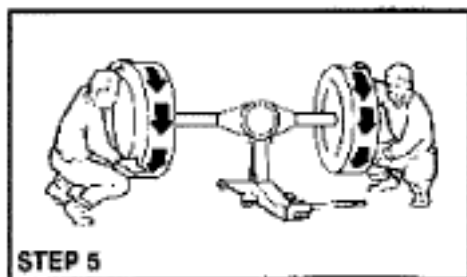
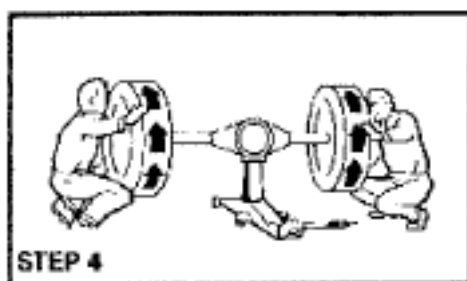
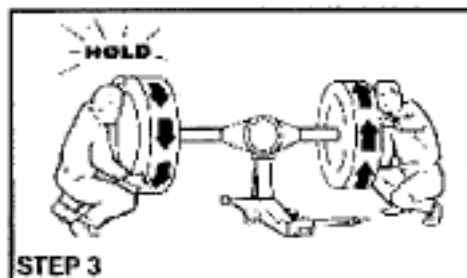
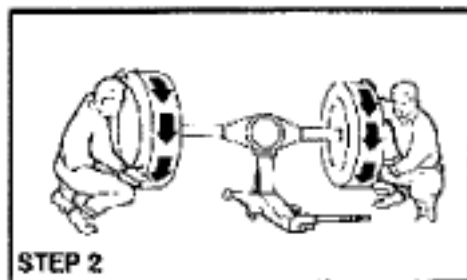

Caution:
When servicing any driveline components of a NoSPIN differential equipped axle, ensure that the engine is switched off and all wheels are free of the ground to prevent the vehicle from moving. Axles equipped with NoSPIN/Detroit Locker differentials deliver power to both wheels - even when only one wheel is on the ground. Failure to observe these cautionary measures may cause the vehicle to move which can result in a mishap which can cause property damage, personal injury, even death.

Caution Label:

Vehicles equipped with NoSPIN differentials should be identified by a Caution label mounted on the instrument panel.

Lubrication:

All NoSPIN differentials are designed to operate in those lubricants recommended by the vehicle/axle manufacturer. No special lubricant is needed. For very cold weather applications, use the lightest oil the axle manufacturer will allow to overcome possible sluggish re-engagement of the driven clutch assemblies.

Routine Inspection

Carefully follow the recommended lubrication, preventative maintenance and inspection procedures of the vehicle/axle manufacturer as part of all NoSPIN differential preventative maintenance. Except for testing for proper operation, and a possible change in the way brake adjustments are made (as explained below), maintenance, inspection and lubrication requirements of NoSPIN differential equipped vehicles are the same as for vehicles with standard differentials.

Check for Proper Operation of NoSPIN Differential

At 90 day intervals, the drive axles should be raised and the NoSPIN differential checked (see page 12) to be sure it is operating properly. This test will also determine if both axle shafts are intact.

Adjustments

No adjustments or alterations should be made to the NoSPIN differential. Refer to the vehicle/axle manufacturer's instructions for adjustments to other components in the axle. When making brake adjustments, the wheels on both sides of the vehicle must be raised and the transmission placed in neutral so that the ring gear and opposite wheels are free to rotate with the wheels on the side being adjusted.

Servicing NoSPIN Differentials

Any decision to disassemble the axle for inspection should be made only after performing the installation and operation tests stated on page 12 and after consulting the vehicle/axle manufacturer's manual and determining that the NoSPIN differential, or some other axle component, is not working properly. Review the "Trouble shooting" section on pages 17-18 to determine whether the situation requires removal of the NoSPIN differential from the vehicle.

Removal of the NoSPIN Differential From the Axle

Refer to the vehicle/axle manufacturer's instructions. The procedure for removing the NoSPIN differential case and ring gear assembly is the same as for the original differential. It is not necessary to remove the ring gear from the differential case half unless the standard support case is being replaced or the NoSPIN differential was supplied with a case manufactured by Tractech.

Retaining Bolt

A retaining bolt, washers and wing nut are useful to keep the NoSPIN differential assembly intact when removing it from the differential case and when reinstalling it in the axle housing.

CAUTION:
FAILURE TO USE A RETAINING BOLT OR SOME OTHER RESTRAINING MEANS WHEN SEPARATING THE DIFFERENTIAL CASE HALVES CAN CAUSE INJURY IN THAT NoSPIN DIFFERENTIALS HAVE COMPRESSED SPRINGS.

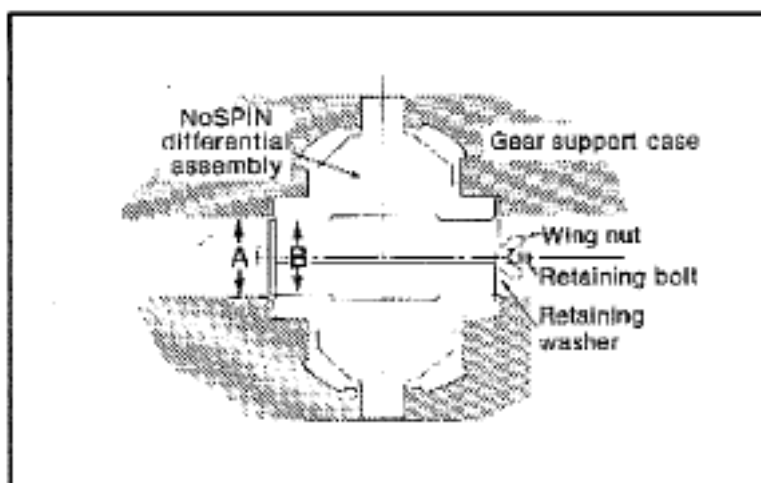

The bolt washers and wing nut used to retain the NoSPIN differential assembly when it was shipped from the factory as illustrated on page 13, are best for this purpose. You will note that the retaining washers must be small enough to pass through the case ends (dimension "A"), yet large enough to restrain the two side gears (dimension "B") and the balance of the NoSPIN differential assembly when all parts are assembled and the springs are compressed.

Disassembly of the NoSPIN Differential

1. Mark the differential case halves so they can be reassembled in their original position when repair or inspection is completed.
2. Insert the NoSPIN differential retaining bolt and washer assembly. Thread the nut fingertight against the washer (Fig 3) if a retaining bolt and washer assembly are not available, *hold the differential case firmly as the last bolts are being removed from the case halves to absorb spring pressure and prevent possible injury.*

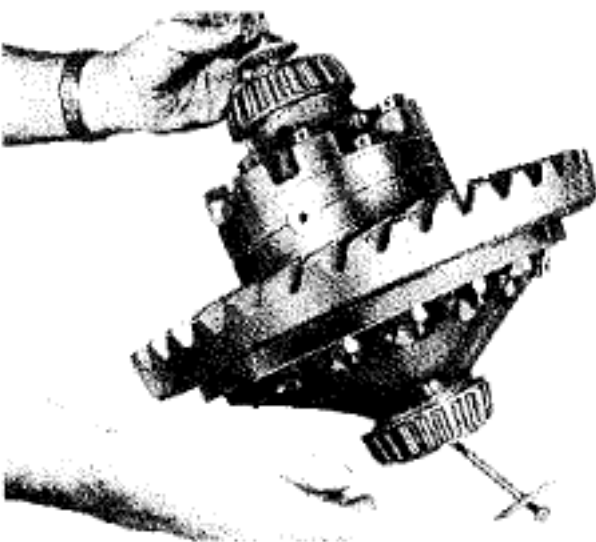

Fig. 3

3. Separate the case halves and remove the NoSPIN differential assembly.
4. Release the retaining bolt and washer assembly while firmly holding the NoSPIN differential to absorb the spring pressure.
5. Remove side gears, springs, spring retainers, driven clutch assemblies and spider assembly.

Inspection of Components

1. Wash all components thoroughly with a non-flammable solvent that will not etch, scratch or oxidize the parts. Rinse in clean solvent and dry.

2. Inspect the splines on the driven clutches. Remove any burrs or small chips with an abrasive stone or electric burr grinder. If sections of the spline are broken away, replace the components.

Inspect the teeth on the driven clutches. If wear or chipping is present, replace the component. *Check holdout rings for fractures and chipping or excessive wear of the lugs. Replace as required.*

NOTE: The holdout ring and driven clutch are serviced as an assembly.

3. Inspect the teeth on the spider and center cam. If wear or chipping is present, replace the component. *Check the center cam for free movement.*

NOTE: The spider and center cam are serviced as an assembly.

4. Inspect the splines on the side gears. Remove any burrs or small chips. If splines are broken or badly chipped, or if hub walls are fractured, replace the component. Inspect the side gear spline fit on its mating axle shaft. Be sure the splines do not bind.

5. Check the spring load at the operating height. (See chart on page 16)

6. Carefully examine the differential case. If worn or scored, the case should be replaced.

7. Examine the bearings, ring gear, ring gear bolts and nuts. Replace if necessary with new components that meet the vehicle/axle manufacturer's specifications.

CAUTION:

If major components (e.g. spider assembly or driven clutch assemblies) show excessive wear, the complete NoSPIN differential should be replaced. If a component is replaced, mating components should also be replaced in that it is likely that they too are damaged. Use of worn or damaged components can lead to a recurrence of the original problem. NOTE: Use only Tractech approved components when repairing NoSPIN/Detroit Locker differentials.

Reassembly Procedure for NoSPIN Differentials

1. Assemble a spring retainer over the side gear splines with the retaining lip pointed up. It should seat against the side gear shoulder. Place a spring over the side gear spline and against the retainer lip with the smaller diameter of the spring against the retainer (Fig. 4).

Fig. 4



NOTE: Verify that the spring is functioning freely. Be sure the spring is not binding, that the coils do not overlap and that there is good contact between the coil and the spring retainer.

2. Assemble the two clutch assemblies to the spider assembly.

IMPORTANT:

Be sure the 'slot' in each holdout ring is properly aligned over the long tooth of the spider assembly.

3. Position the spider assembly and clutch assembly on top of the spring.

4. Assemble the other retainer and spring on the other side gear as previously indicated, and position on top of the spider and clutch assembly.

5. Using a mechanical press (or other safe means) compress the springs and fasten the NoSPIN together with a retaining bolt, washers and wing nut (Fig. 5). Be sure the side gear splines are completely meshed with the clutch spline.

Fig. 5

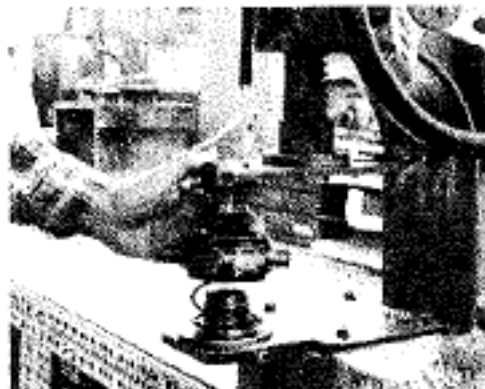

CAUTION:

Failure to use a retaining bolt or some other restraining means when assembling the NoSPIN can cause injury in that all NoSPIN differentials have compressed springs.

6 Lay the ring gear and flanged half of the differential case on a bench with the bearing end of the case hub down and the inner case facing up. **ENSURE NO THRUST WASHERS ARE INSIDE THE CASE.**

7. Install the NoSPIN differential in the flanged differential case half.

8. Mount the plain case half over the side gear. **ENSURE NO THRUST WASHERS ARE INSIDE THE CASE.**

9. Position the case halves firmly together with the punch marks aligned and install the case bolts.

10 Tighten case bolts to the torque specified by the vehicle/axle manufacturer. Check to be certain of a tight fit between the two case halves at all points and between the trunnion mounts in the case and the spider trunnions (Fig. 6).

Fig. 6

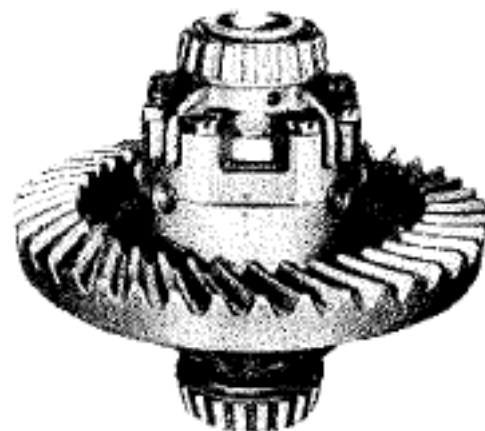

11. Remove the wing nut, washers and retainer bolt.

12. Follow the vehicle/axle manufacturer's instructions for reinstallation of the ring gear and differential case assembly into the axle carrier.

13. **BEFORE OPERATING THE VEHICLE PERFORM INSTALLATION AND OPERATION TEST STATED ON PAGE 12 TO ENSURE CORRECT RE-ASSEMBLY OF COMPONENTS.**

Spring load should be checked at the operating height specified in the above table for an approximate reading. A dial indicator type spring tester is the best tool for this procedure. However, if one is not available, a weight equal to the load specified in the table can be placed on the spring and the height can be measured with the weight in place on the spring. Tech Data Report #80-1038 can be used to assist in making a decision as to whether the spring should be replaced.

Model Series	Part No.	Operating Height	Load (lbs. Minimum)
137S	69978	.45"	40
162S	69427	.54"	45
187S	68264	.61"	46
187S	69076	.61"	72
187S	72008	.61"	72
187S	72016	.61"	72
225S	66622	.73"	53
225S	69640	.73"	52
250S	67085	.62"	61
275S	67115	.86"	69
306S	66842	.90"	104
350S	67204	1.04"	101
400S	65461	1.41"	144
450S	64718	1.30"	162
550S	65423	1.43"	198
600S	68707	1.56"	297

An important function of an owner/operator in the field is that, one of the many hats he is required to wear is the one labeled "trouble shooter." Trouble shooting can be a very frustrating, elusive job. However, if some basic rules are followed in a systematic order, solutions can be easily obtained. The following guidelines can be utilized for trouble shooting both on and off highway vehicle applications. However, some techniques used for on/highway vehicles are not as important for off/highway vehicles:

1. Before tearing down an axle and differential make sure you get the correct "story" from a reliable source. Then actually try the vehicle yourself, inspect any previously remove components, Question associated failures, ask if it has occurred before. In other words, get the facts. And don't over-react.
2. Read the Trouble Shooting Section. (Enclosed)
3. Perform a Functional Check. (Enclosed)
4. Check tire rolling radii. Assure that all tires are within specifications. (This applies primarily to on/highway vehicles.)
5. If all the previous checks do not reveal the problem or offer a solution, then the NoSPIN must be removed. Upon removal, look for the following:
 - A. Contamination in the oil or on the components.
 - B. Obvious broken or worn parts.
 - C. Mis-assembly...i.e., retainers installed backwards, thrust washers left in, spring jumping over retainer, etc.
 - D. Heavy wear on spider and clutch drive teeth... i.e., Tooth rounding, 5° negative angle gone, corner chipping of teeth. (These components are usually the main areas of wear.)
 - E. Telltale signs of eccentric wear, patterns on components, indicating possible cause of shaft problems.
 - F. Check NoSPIN assembly for pair-up, hand cam, H.O.R. tension, backlash, etc.
6. After inspection of the NoSPIN and associated axle components a new unit should be installed and a complete functional check and vehicle performance check should be made.
7. If during the visual inspection a solution to the problem is not obtained, the unit should be returned to Tractech attention of the Customer Services Manager. Call first for a return authorization number.

The following chart will assist owners and operators of NoSPIN differential equipped vehicles diagnose and correct problems related to vehicle performance. Potential problems are stated on the left; possible causes for those problems are listed, by number, on the right. The explanation of these "possible causes" follows on page 18.

PROBLEM	POSSIBLE CAUSE														
	1	2	3	4	5	6	7	8	9	10	11	12	13	14	15
Hub studs shearing; rear tire scuffing; axle shaft breakage	●	●			●			●	●					●	
Steering difficulty; vehicle pulls on straight forward driving or tends to go straight when making turns	●	●	●	●	●		●		●				●	●	
No differential action; binding in turns	●			●	●	●			●					●	●
Excessive driveline noise*	●	●	●	●	●		●		●					●	
Excessive tire wear	●	●	●	●	●	●	●							●	●
Grinding noises	●			●	●			●	●	●				●	
Continuous "clicking" sound in straight forward driving	●	●	●		●										
Excessive backlash in vehicle drivetrain; engine lug or vehicle surge during turns	●					●		●		●					
Tendency to side-slip or "fishtail" on icyroads											●				
Sluggish reengagement of NoSPIN differential clutch assemblies									●			●			
Difficulty in turning vehicle from standing start	●			●	●								●	●	
Erratic operation of NoSPIN differential; premature wear or failure of NoSPIN differential components	●	●	●	●	●			●	●	●		●		●	

* NOTE: NoSPIN differentials will emit occasional "metallic" sounds due to backlash built into the unit. This is normal! See backlash under Vehicle Performance on pages 4.

Possible Causes for Vehicular Problems

1. Improper installation; defective NoSPIN differential. Follow test procedures outlined on page 12 Correct installation or repair or replace the NoSPIN differential if the vehicle fails any step of the test procedure.
2. Overloading and/or improper weight distribution. Remove excess weight and redistribute the load from side to side, according to the vehicle/axle manufacturer's instructions.
3. Unequal rolling radii of the drive wheel. A smaller rolling radius tire will cause the tire to overrun constantly when power is applied. The other tire (with the larger rolling radii) will do all the driving replace tires or adjust tire pressures until rolling radii are equal.
4. Broken axle shaft. Replace. NOTE: It is possible to operate a NoSPIN equipped vehicle on one axle shaft. However, this practice is not recommended in that serious damage can occur to other axle components.
5. Bent axle shaft or housing; axle shafts on different center lines. Replace bent axle shafts or housing or realign hub faces and bolt circles in both the differential carrier and axle housing.
6. Larger than normal steering angle; short turning radius. Vehicles designed with high turning angles may surge, have steering difficulty and cause tire wear during sharp turns. Reduce maximum turning angle and have the driver decelerate when engine surge begins.
7. Incorrect wheel alignment. Correct as required.
8. Worn or defective axle components. Check the condition of the ring gear, pinion gear, bearings, seals, etc. Replace as required.
9. Foreign matter in axle housing or improper assembly of axle components. Inspect for contamination. Check assembly of axle components.
10. Incorrect ring and pinion adjustments; worn driveline components (transmission gears, U-joints, etc). Replace or adjust components as required.
- 11 High crown in road; poor traction surface under all drive wheels. The tendency to side-slip or 'fishtail' on icy roads sloping toward the curb is more pronounced when using a traction differential than when using a conventional differential. Stability can be retained when side-slip occurs by decelerating (letting off the accelerator). CAUTION: Do not apply the brake. To do so may result in loss of vehicle control.
- 12 High Viscosity Lubricant. In very low temperatures, gear lubricant can thicken and impede the normal function of the NoSPIN differential. Tractech recommends that the axle oil be changed for very cold weather operation to the lightest acceptable lubricant allowable by the axle/vehicle manufacturer. Heat control devices, garaging and a warm up period may also provide relief from this problem in extreme low temperatures.
- 13 Low steering cylinder pressure, undersized steering cylinder, excessive angle of articulation, excessive vehicle weight. Correct as required.
- 14 Improper application of product. Review application guidelines on pages 3.
- 15 Insufficient front axle overrun ratio (lead) for (arm tractors (straight frame with front wheel assist power) Take physical measurement increase to minimum of plus three (+3) percent by increasing tire pressure in front tires and/or reducing tire pressure in rear tires, within the tire manufacturer's recommendations.

SPECIAL INSTRUCTIONS

TO IDENTIFY

New IMPROVED Detroit Locker differential models in the 187S and 225S series' have an "L" added to the model number, such as 187SL-16A. They replace the previous model.

APPLICATIONS

These units are designed for light trucks including 2 wheel drive and 4 wheel drive vehicles and high performance passenger cars.

VEHICLE PERFORMANCE

Performance is similar to that of NoSPIN/Detroit Locker - equipped light trucks, pages 3-4. The new IMPROVED Detroit Locker operates in the drive - coast mode without the familiar harsh feel and sound. Everyday driving is quieter and smoother, yet maximum traction is immediately available.

EXPLODED VIEW

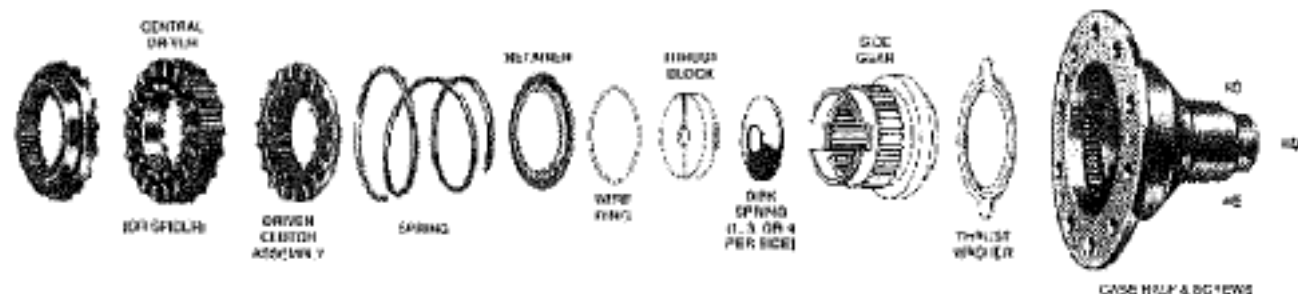

Note the additional parts compared to NoSPIN/Detroit locker differentials, page 5. New IMPROVED Detroit Locker models are supplied with either a spider or central driver and a support case.

OPERATION

Operation is identical to that of NoSPIN/Detroit Locker - equipped vehicles, page 6.

INSTALLATION

Installation of a new IMPROVED Detroit Locker is similar to that of a NoSPIN/Detroit Locker differential, pages 7, 10 and 11. Important: Thrust washers are supplied installed inside the support case. The instructions on pages 8, 12 and 15 to "Be sure all thrust washers have been removed" DOES NOT APPLY to the two thrust washers supplied with the new IMPROVED Detroit Locker models.

Caution: If for any reason the thrust washers supplied have been removed from the support case halves supplied, reinstall only the two thrust washers supplied by Tractech by locating the tabs in slots, with the oil groove facing you.

Caution: If for any reason the new IMPROVED Detroit Locker unit is disassembled, reinstall the disc (Belleville) springs - there will be one, three or four on each side - with the large diameter against the side gear.

Be sure to install the Caution label and this Manual in the vehicle.

TEST FOR PROPER INSTALLATION AND OPERATION

Perform this test as described on page 12.

MAINTENANCE

Follow the instructions and cautions as described on pages 13-16 except that the instruction on page 16 to "Be sure all thrust washers have been removed" DOES NOT APPLY to the thrust washers supplied with the new IMPROVED Detroit Locker models.

TROUBLE SHOOTING

The help provided on pages 17-18 apply to the new IMPROVED Detroit Locker differential.

SPECIAL INSTRUCTIONS

Detroit Lockers for C-Clip retained axles in the 187 and 225 series have a "C" instead of an "S" in their model number, such as 187C-145A.

APPLICATIONS

These units are designed for light trucks including 2-wheel-drive and four-wheel-drive vehicles, and high performance passenger cars.

VEHICLE PERFORMANCE

Performance is identical to that of NoSPIN/Detroit Locker - equipped vehicles, page 4.

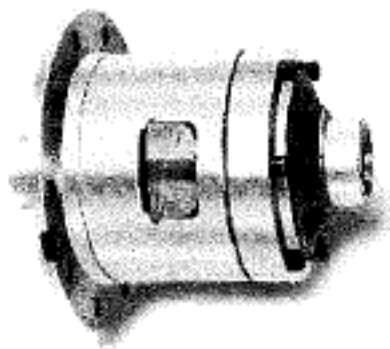

EXPLODED VIEW

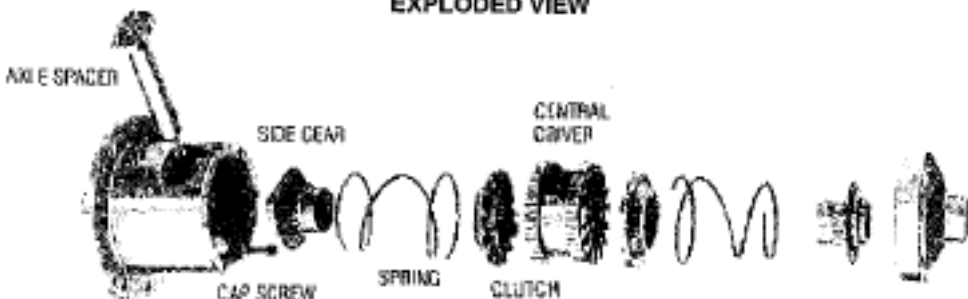

C-Clip Installation

OPERATION

Operation is identical to that of NoSPIN/Detroit Locker - equipped vehicles, page 6.

INSTALLATION

Installation of a Detroit C-Locker for differential is similar to that of a Detroit Locker differential, pages 7-11 up to Step 11. The following steps must be carried-out before proceeding to Step 12.

Step 11a Install the differential and ring gear assembly in the axle, setting pre-loaded and backlash per the vehicle manufacturers instructions. Note: Contamination, such as metal particles in the differential case, can cause the differential to malfunction. Be sure the axle housing is clean before proceeding.

Step 11b Install the C-Clip as in the conventional differential utilizing the window in the side of the differential case.

Step 11c If the plain side (the side opposite the ring-gear side) bearing cap has already been installed, it will be necessary to remove it before proceeding.

Step 11d Install the spacer pin (in plastic bag) through the case and between the ends of the axle shafts.

Step 11e Insert the long socket-head cap screw (in plastic bag) through the differential plain-side cover and thread into differential housing. The end of the screw will engage the hole in the spacer pin thus holding it in place. Torque the screw to 23-25 ft.-lbs. (31-34Nm). Note: this screw has a thread locking patch pre-applied to it. If for any reason it is removed after installation, a thread locking compound must be re-applied before reassembly.

Step 11f Install the plain-side bearing cap and torque per the vehicle manufacturer's instructions. Bearing cap bolts must have a thread locking compound applied to them.

Step 11g Complete the reassembly of the associated components as recommended by the vehicle manufacturer's instructions.

Complete Steps 12, 13, and 14 on page 9. Be sure to install Caution Label and this Manual in the vehicle.

TEST FOR PROPER INSTALLATION AND OPERATION

Perform this test as described on page 12.

MAINTENANCE

Follow the instruction and Cautions as described on pages 13-16.

TROUBLE SHOOTING

The help provided on pages 17-18 apply to the Detroit C-Locker for C-Clip retained axles.

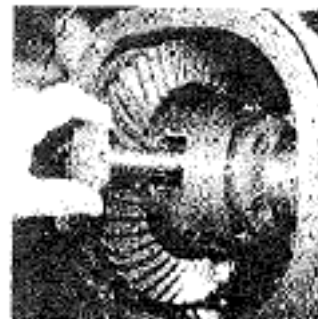

CONTACT OUR SERVICE OR PARTS DEPARTMENT WITH ANY QUESTIONS

SERVICE

Chittenango: 800-962-5768
Daryl Wallace or Brian Lamaitis

Rochester: 800-463-3232
Melinda LaDue

Albany: 866-867-1100
Ben Reiling

Warranty: 800-962-5768
Morgan Jenkins

Customer Service Representatives

Eastern Region:
Gary Bigness
845-500-3707

Central Region:
JJ Richmond
315-559-3999

Western Region:
Mike Panzica
716-908-3186

PARTS

Director of Parts
Jim Hogan
jhogan@newyorkbussales.com
607-227-5794

Chittenango: 800-962-5768
Gari McQuade
gmcquade@newyorkbussales.com
Bill Cox
bcox@newyorkbussales.com
John Lewin
jlewin@newyorkbussales.com
Dave Grant
dgrant@newyorkbussales.com

Albany: 866-867-1100
Sean Conway
sconway@newyorkbussales.com
John Green
jgreen@newyorkbussales.com

Rochester: 800-463-3232
Dave Cook
dcook@newyorkbussales.com
Steve Hibbard
shibbard@newyorkbussales.com
Ryan Krolak
rkrolak@newyorkbussales.com

ALL of our Service Updates can be found on the [New York Bus Sales website](#)
Or at the [New York Head Mechanic website](#).

