

# BENDIX AIR DISC BRAKES

## SALES UPDATE #16-05

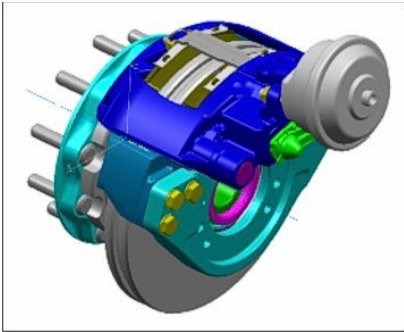

### DUST SHIELDS ON AIR DISC

Recently, New York Bus Sales and Bendix did a “Hands On” training session on the Air Disc brake system available on the Blue Bird product. During the training the instructor mentioned the optional “pad” dust shield and “rotor” dust shield (#29 & #30- Figure #1) which we have provided as part of our brake package. Currently the “pad” dust shields are on both the front and rear while the “rotor” dust shield is only available on the rear. These shields are NOT required and as the Bendix trainer explained do impede Techs from visually inspecting pads in the front AND rear as well as the rear rotors. The instructor also pointed out that the brake is very robust and can stand the road abuse and dirt from a Northeast winter.

ALL of our Service Updates can be found on the [New York Bus Sales website](#)  
Or at the [New York Head Mechanic website](#)

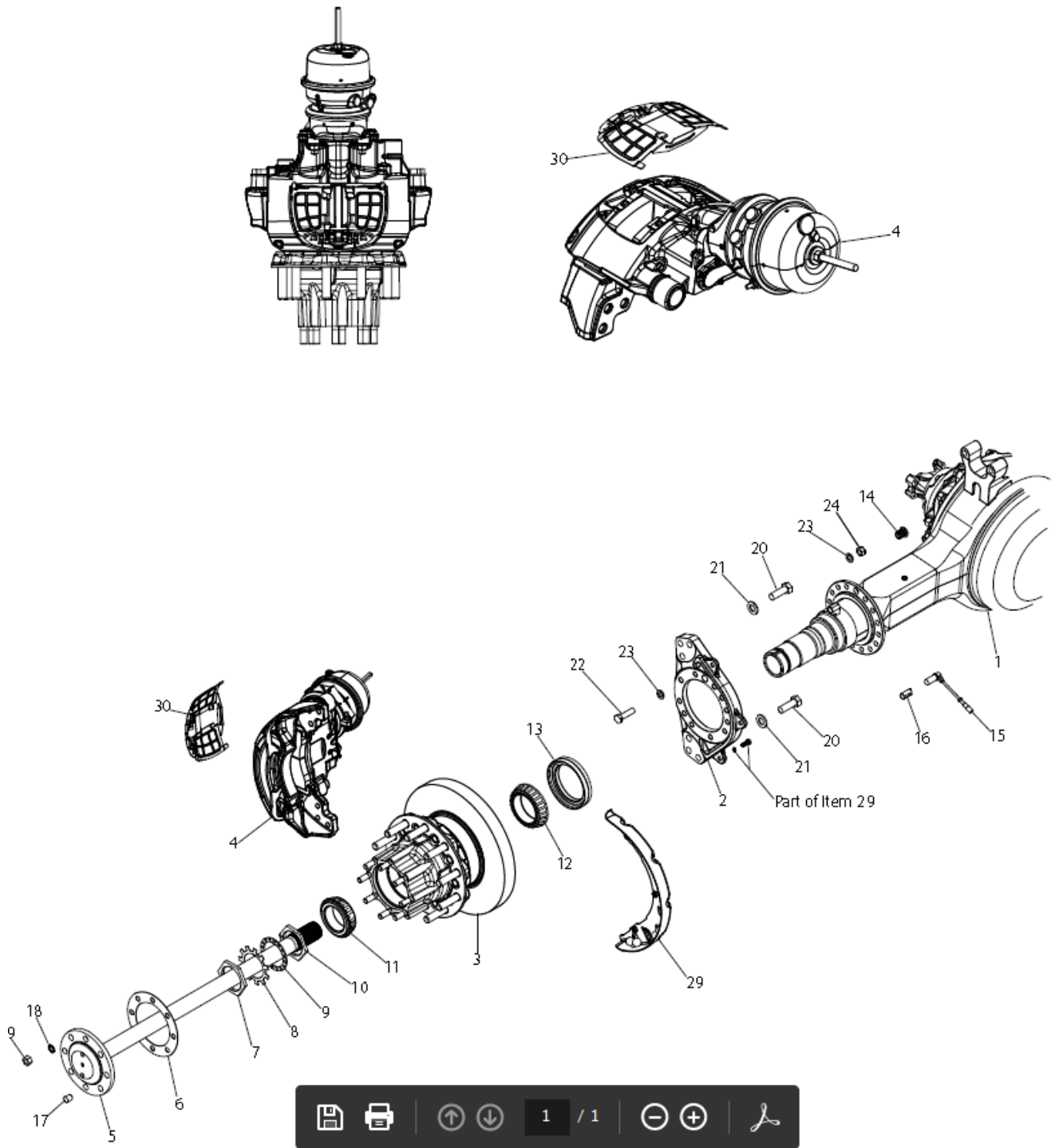

FIGURE #1

ALL of our Service Updates can be found on the [New York Bus Sales website](#)  
 Or at the [New York Head Mechanic website](#)



# Bendix® ADB22X™ Air Disc Brake

## Basic Concepts & Functional Understanding

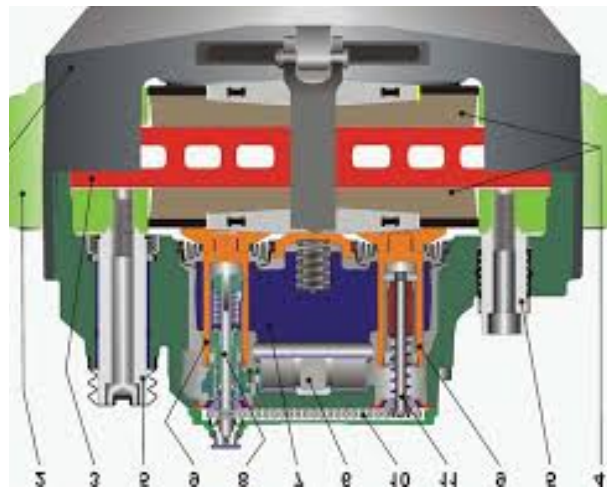
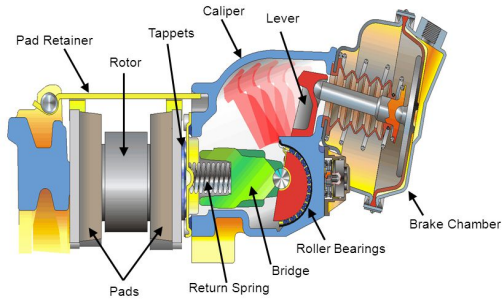

For Bendix® Air Disc Brakes, as a vehicle travels forward, the wheel always rotates towards the fixed-pin side of the caliper first.

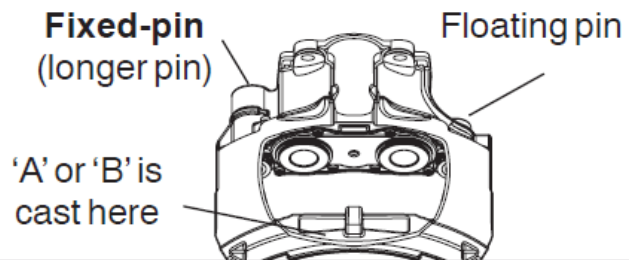

Type 'A'	Type 'B'
<p>Wheel Rotation</p>	<p>Wheel Rotation</p>

On most vehicles, Type A calipers are used on the passenger's side of the vehicle. (There are some rare driver's side applications.)

On most vehicles, Type B calipers are used on the driver's side of the vehicle. (There are some rare passenger's side applications.)

ALL of our Service Updates can be found on the [New York Bus Sales website](#)  
Or at the [New York Head Mechanic website](#)



**PLEASE NOTE:**

**OPTION #40049-01 IS FOR THE PAD DUSTSHIELDS AT THE FRONT AND REAR ALONG WITH THE REAR ROTOR DUSTSHIELDS. WHEN ORDERING, PLEASE SPECIFY WITH YOUR SALES REPRESENTATIVE IF YOU WOULD LIKE THIS OPTION OR NOT.**

ALL of our Service Updates can be found on the [New York Bus Sales website](#)  
Or at the [New York Head Mechanic website](#)



## CONTACT OUR SALES DEPARTMENT WITH ANY QUESTIONS

**Kevin Coon**

**kcoon@newyorkbussales.com**

315-415-6570

**Bill Daigler**

**wdaigler@newyorkbussales.com**

716-713-9852

**George Darling**

**gdarling@newyorkbussales.com**

315-263-6141

**Jeremy Johnston**

**jjohnston2@newyorkbussales.com**

585-233-3768

**Bill Lyons II**

**wlyons2@newyorkbussales.com**

518-275-2816

**Jeremie (JJ) Richmond**

**jrichmond@newyorkbussales.com**

315-559-3999

ALL of our Service Updates can be found on the [New York Bus Sales website](#)  
Or at the [New York Head Mechanic website](#)

