

BBCV Radiator Isolators

Tech Tip #14-1124REVA

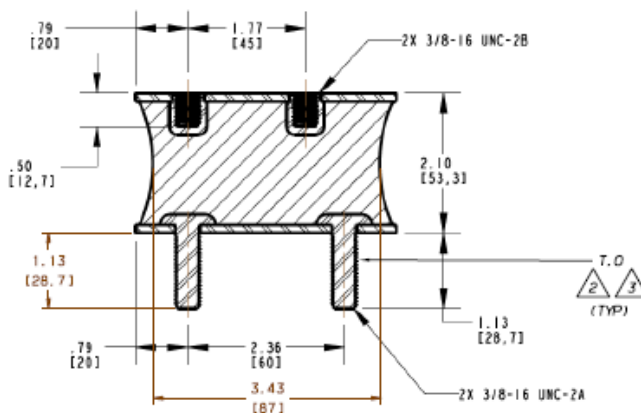
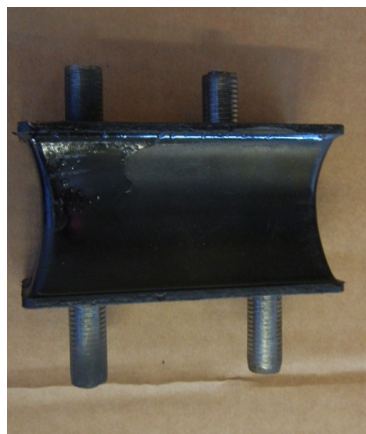

July 26, 2017 – New Isolators Released

UPDATE: A new style isolator has been released to help address concerns previously discussed. The new isolator design requires two part numbers, one for the actual isolator and one for the two bolts which have replaced two of the studs which were previously part of the isolator.

Figure #5 shows the new isolator and Figure #6 shows the related bolts.

NEW ISOLATOR PART

10048325

REQUIRED BOLTS PART

#10048721(2)

PLEASE NOTE: New Isolators went into production on propane units May 4, 2017 and on Cummins Diesel July 24, 2017

ALL of our Service Updates can be found on the [New York Bus Sales website](#)
Or at the [New York Head Mechanic website](#)

- **Complaint –** There is a clicking noise in the front end especially on turns.
- **Cause –** On older units we have seen the side mounted radiator isolators, #4 in FIGURE #1 for Diesel units and #3 in FIGURE #2 for Propane units, come apart causing the radiator to “lift” in turns and then settle back down, which may cause the “clicking” noise in turns. Looking at the unit during a normal PM you would not notice that there was any issue. If they have separated they could separate as shown in FIGURE #3.
- **Correction –** During PM inspections lifting on the radiator or at the isolators on the frame rail to assure they have not split will ensure there are no issues. If they have split it would be recommended to change both to ensure no further problemsa new one is shown in FIGURE #4

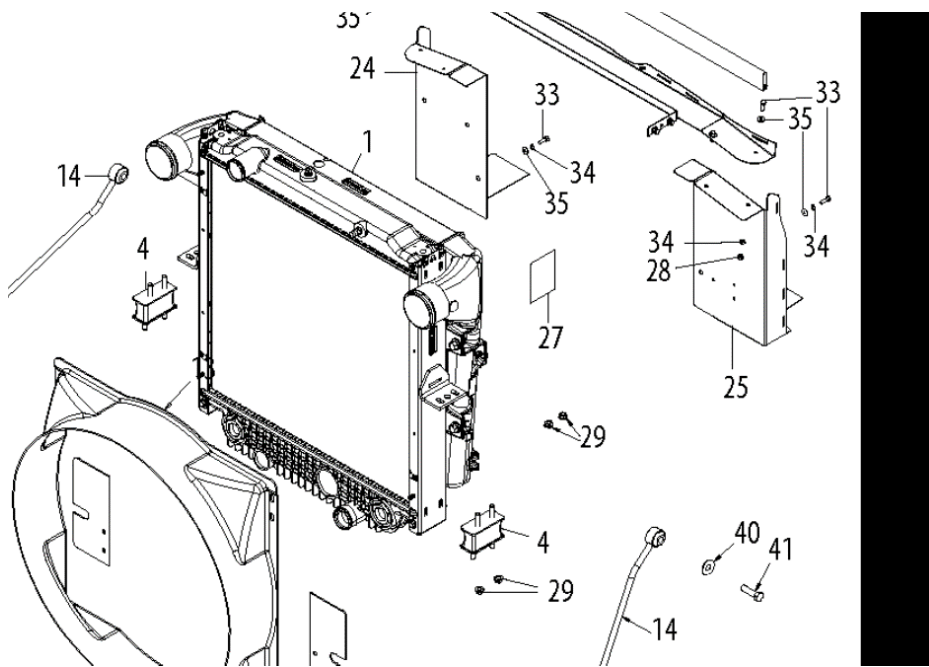

FIGURE #1

ALL of our Service Updates can be found on the [New York Bus Sales website](#)
Or at the [New York Head Mechanic website](#)

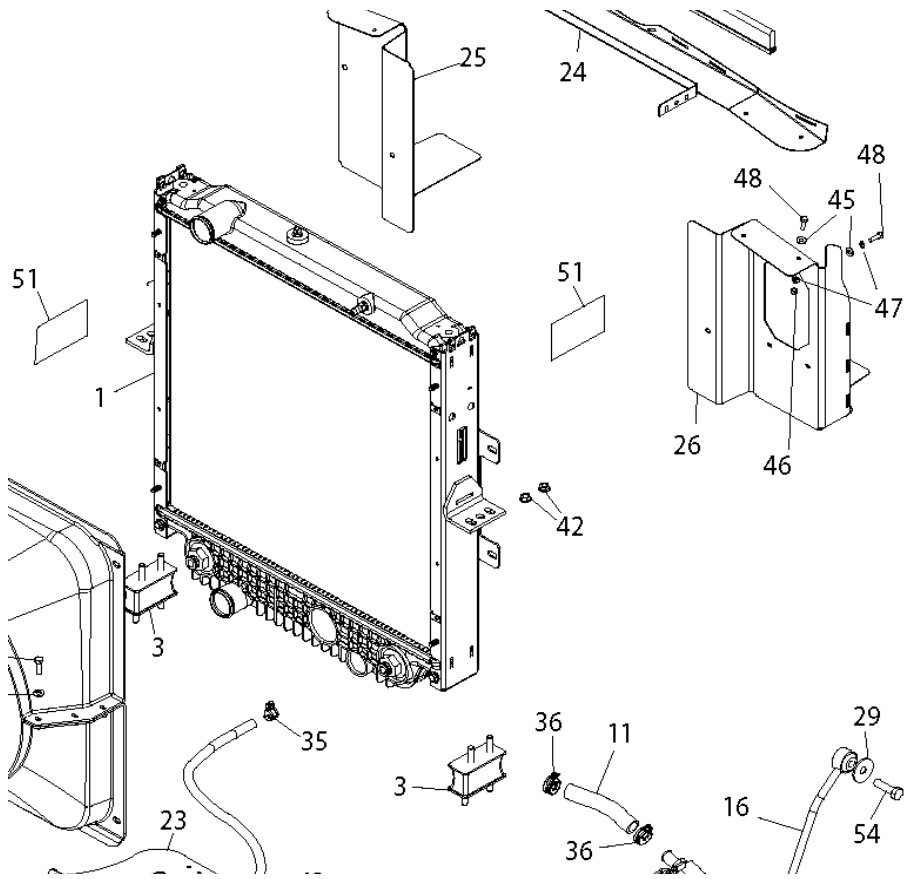

FIGURE #2



FIGURE #3

ALL of our Service Updates can be found on the [New York Bus Sales website](#)
Or at the [New York Head Mechanic website](#)

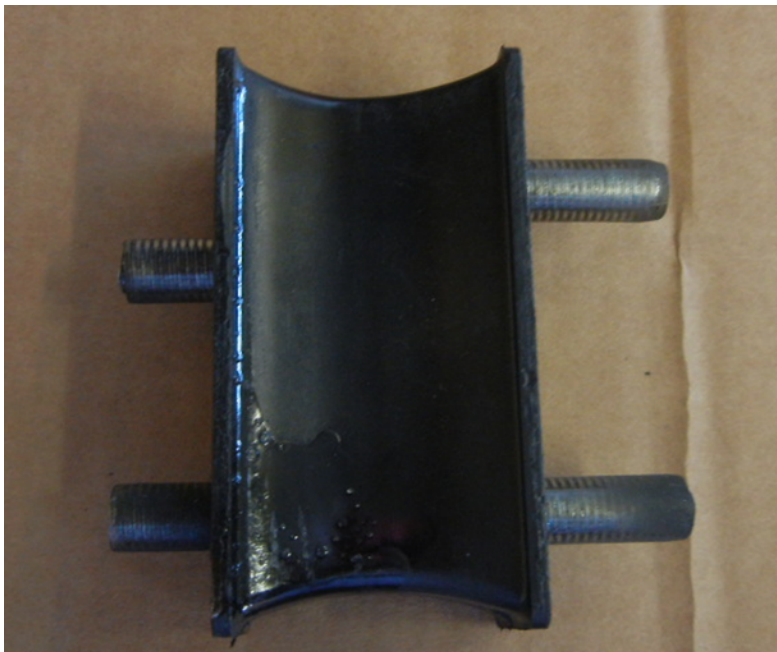
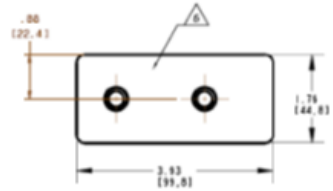

FIGURE #4
ISOLATOR PART #00048444

ALL of our Service Updates can be found on the [New York Bus Sales website](#)
Or at the [New York Head Mechanic website](#)





- △ MATERIAL:
METAL PART - SAE 1010/1020
ELASTOMER - NATURAL RUBBER 75 DIAMETER
STILES - SAE GRADE B
- △ SURFACES MARKED T* MAY HAVE A TIGHT SKIN OF ELASTOMER.
SURFACES MARKED T.O TO BE FREE OF ELASTOMER.
- △ SURFACES MARKED T.O TO BE FREE OF ADHESIVE OVERSPRAY.
SURFACES MARKED T* MAY HAVE ADHESIVE OVERSPRAY.
- 4. COMPRESSION STIFFNESS: 800 ±100 LB/IN
(1541.1 ±227.7 N/MM)
- 5. BOND STRENGTH: 150 P.S.I. MIN AT 150° F.
- △ DIMENSIONS OF MARK IN APPROPRIATE LOCATION INDICATED WITH:
MANUFACTURER NAME
PART NUMBER
DATE OF MANUFACTURE
- △ DIMENSIONS ARE IN INCHES. DIMENSIONS IN [] ARE IN METRIC.
TOLERANCES:
X.X ± .05
X.X X ± .03
X.XXX ± .01
- △ FINISH: ZINC PLATE

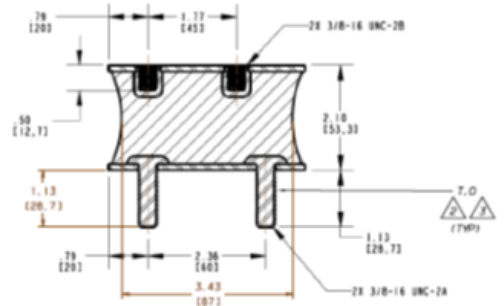

DB #	ESCD #	DIAMETER	MAX. AXIAL DEFLECTION (L/IN)	MAX. AXIAL LOAD (LB)
10044325	6751-88	75	.20	1800

Figure #5

ALL of our Service Updates can be found on the [New York Bus Sales website](#)
Or at the [New York Head Mechanic website](#)



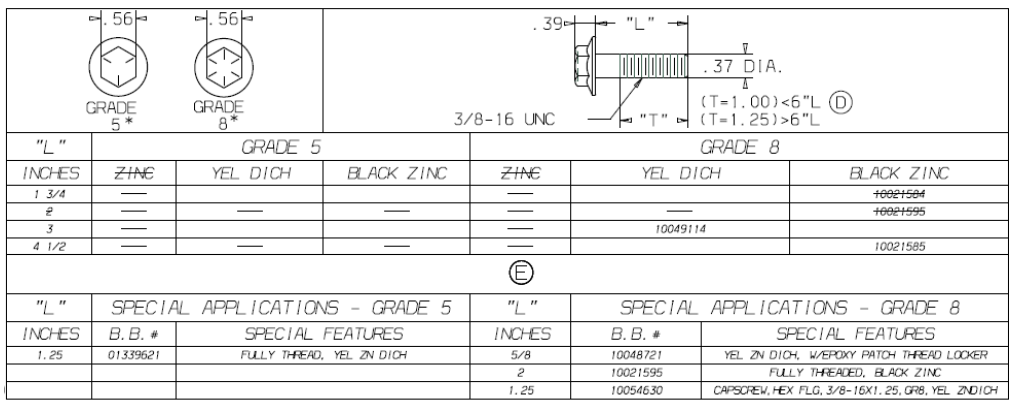

Figure #6

**THANK YOU TO HARRY & JEREMY FROM
DUANESBURG CENTRAL SCHOOL FOR BRINGING
THIS TO OUR ATTENTION!!!**

ALL of our Service Updates can be found on the [New York Bus Sales website](#)
Or at the [New York Head Mechanic website](#)



CONTACT OUR SERVICE OR PARTS DEPARTMENT WITH ANY QUESTIONS

SERVICE

Chittenango: 800-962-5768
Daryl Wallace or Brian Lamaitis

Rochester: 800-463-3232
Dave Schaub

Albany: 866-867-1100
Ben Reiling

Warranty: 800-962-5768
Morgan Jenkins

**Customer Service
Representatives**

Eastern Region:
Gary Bigness
845-500-3707

Central Region:
JJ Richmond
315-559-3999

Western Region:
Mike Panzica
716-908-3186

PARTS

Director of Parts
Jim Hogan
jhogan@newyorkbussales.com
607-227-5794

Chittenango: 800-962-5768
Gari McQuade
gmcquade@newyorkbussales.com
Bill Cox
bcox@newyorkbussales.com
John Lewin
jlewin@newyorkbussales.com
Dave Grant
dgrant@newyorkbussales.com

Albany: 866-867-1100
Sean Conway
sconway@newyorkbussales.com
Pat Murphy
pmurphy@newyorkbussales.com

Rochester: 800-463-3232
Dave Cook
dcook@newyorkbussales.com
Steve Hibbard
shibbard@newyorkbussales.com

ALL of our Service Updates can be found on the [New York Bus Sales website](#)
Or at the [New York Head Mechanic website](#)

