

# Rear Axle Shaft Nuts

## SERVICE NOTICE #17-0922

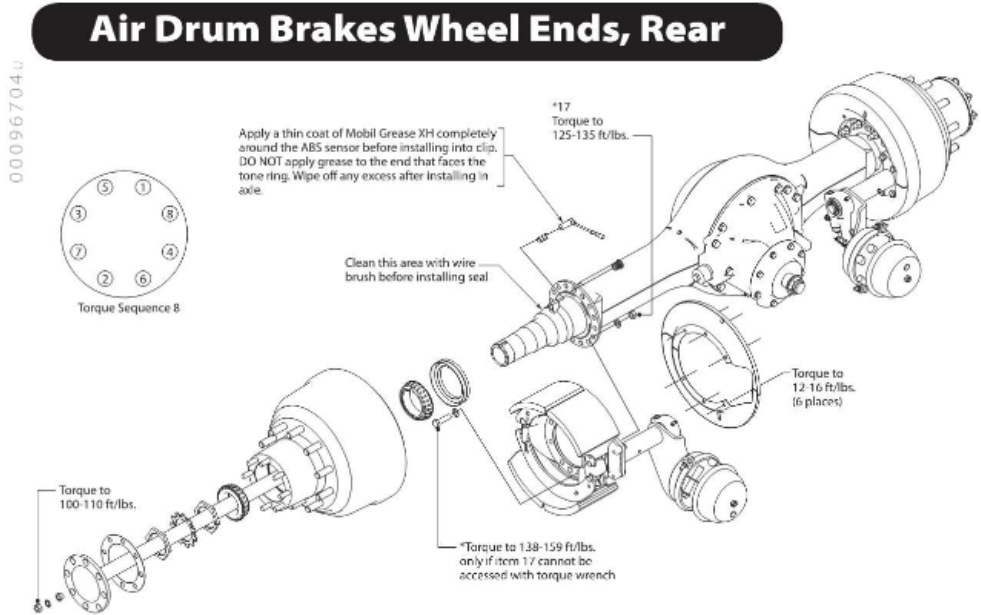

### Rear Axle Shaft Nuts Improperly Torqued Causing Leaks

Several customers have found oil leaking from their rear axles where the axle shaft mounts to the hub. When checked they found that the nuts holding the axles in are not tight.

We have investigated the issue and found that these instances are where we had adjusted wheel bearings, therefore pulling the axles out. When we reinstalled, the proper torque was not used causing the issue.

ALL of our Service Updates can be found on the [New York Bus Sales website](#)  
Or at the [New York Head Mechanic website](#)

We apologize for this inconvenience and are asking ALL customers to check the axle nuts with a torque wrench to make sure they are properly torqued. Drum brakes should be torqued to 100-110ft/lbs and disc brakes to 170-190 ft/lbs per the Blue Bird Service Manual. If you have units where the nuts are loose, we will send you new gaskets, nuts and locks to replace those that are not properly torqued. Please keep track of your labor and we will reimburse you. If replacing, torque should be done in a “star” sequence as in FIGURE #1 below.

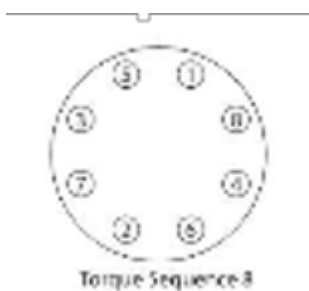

FIGURE #1

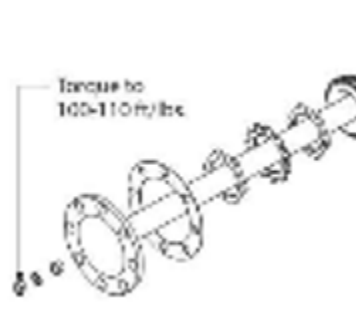

FIGURE #2

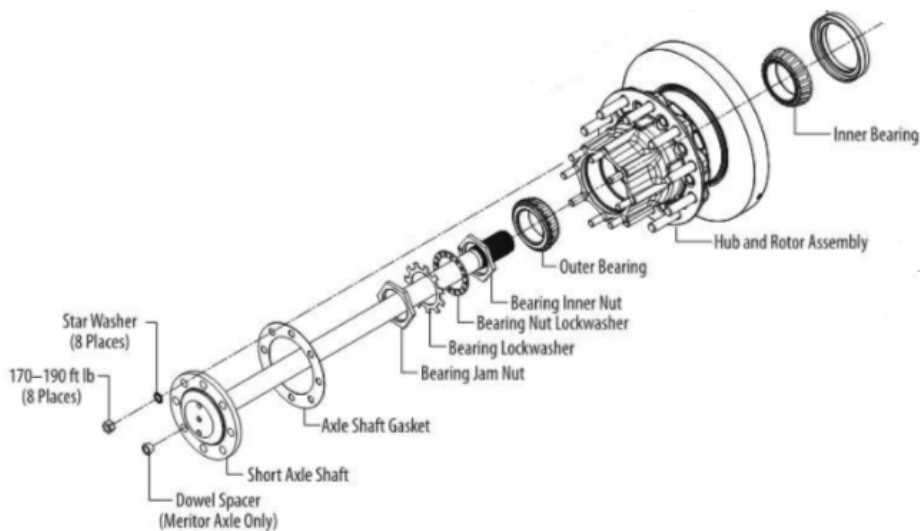

FIGURE #3

ALL of our Service Updates can be found on the [New York Bus Sales website](#)  
Or at the [New York Head Mechanic website](#)

|                    |                  |
|--------------------|------------------|
| <b>AXLE STUD</b>   | <b>#10034840</b> |
| <b>AXLE NUT</b>    | <b>#02001501</b> |
| <b>STAR WASHER</b> | <b>#01540103</b> |
| <b>GASKET</b>      | <b>#10051974</b> |

ALL of our Service Updates can be found on the [New York Bus Sales website](#)  
Or at the [New York Head Mechanic website](#)



## CONTACT OUR SERVICE OR PARTS DEPARTMENT WITH ANY QUESTIONS

### SERVICE

**Chittenango:** 800-962-5768  
Daryl Wallace or Brian Lamaitis

**Rochester:** 800-463-3232  
Dave Schaub

**Albany:** 866-867-1100  
Ben Reiling

**Warranty:** 800-962-5768  
Morgan Jenkins

**Customer Service  
Representatives**

**Eastern Region:**  
Gary Bigness  
845-500-3707

**Central Region:**  
Josh Coon  
315-263-0765

**Western Region:**  
Mike Panzica  
716-908-3186

### PARTS

**Director of Parts**  
Jim Hogan  
jhogan@newyorkbussales.com  
607-227-5794

**Chittenango:** 800-962-5768  
Gari McQuade  
gmcquade@newyorkbussales.com  
Bill Cox  
bcox@newyorkbussales.com  
John Lewin  
jlewin@newyorkbussales.com  
Dave Grant  
dgrant@newyorkbussales.com

**Albany:** 866-867-1100  
Sean Conway  
sconway@newyorkbussales.com  
Pat Murphy  
pmurphy@newyorkbussales.com

**Rochester:** 800-463-3232  
Dave Cook  
dcook@newyorkbussales.com  
Steve Hibbard  
shibbard@newyorkbussales.com

ALL of our Service Updates can be found on the [New York Bus Sales website](#)  
Or at the [New York Head Mechanic website](#)

