

# Roush GEN III & IV Fuel Tank Access

## Tech Tip #18-0605-RP

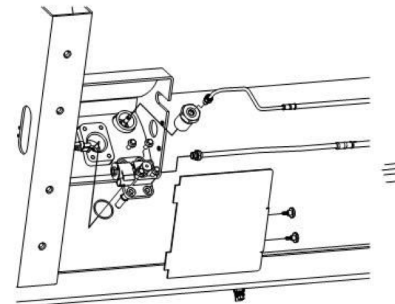

REAR

### Manual Shutoff Access Plate Maintenance

Recently we have had several units where servicing required shutting off the fuel at the manual shutoff.

When we attempted to remove the access plate the screws holding the plate had actually rusted themselves solid and the only way to remove them was to break them free. Please see Figures #2 & #3!

What was even more evident once the plate was removed was the debris that was surrounding the manual shutoff valve. Please see Figure #1 and YES, that is a leaf!

During normal servicing the screws holding the access plate should be removed and lubricated. This ensures that in the event that access to the manual shut off is required that the plate can be easily removed. It would also not be a bad idea to occasionally remove the access plate and remove any debris from around the valve and rinse the area.

ALL of our Service Updates can be found on the [New York Bus Sales website](#)  
Or at the [New York Head Mechanic website](#)



FIGURE #1



FIGURE #2



FIGURE #3

ALL of our Service Updates can be found on the [New York Bus Sales website](#)  
Or at the [New York Head Mechanic website](#)



## CONTACT OUR SERVICE OR PARTS DEPARTMENT WITH ANY QUESTIONS

### SERVICE

**Chittenango:** 800-962-5768  
Daryl Wallace or Brian Lamaitis

**Rochester:** 800-463-3232  
Dave Schaub

**Albany:** 866-867-1100  
Ben Reiling

**Warranty:** 800-962-5768  
Morgan Jenkins

**Customer Service  
Representatives**

**Eastern Region:**  
Gary Bigness  
845-500-3707

**Central Region:**  
JJ Richmond  
315-559-3999

**Western Region:**  
Mike Panzica  
716-908-3186

### PARTS

**Director of Parts**  
Jim Hogan  
jhogan@newyorkbussales.com  
607-227-5794

**Chittenango:** 800-962-5768  
Gari McQuade  
gmcquade@newyorkbussales.com  
Bill Cox  
bcox@newyorkbussales.com  
John Lewin  
jlewin@newyorkbussales.com  
Dave Grant  
dgrant@newyorkbussales.com

**Albany:** 866-867-1100  
Sean Conway  
sconway@newyorkbussales.com  
Pat Murphy  
pmurphy@newyorkbussales.com

**Rochester:** 800-463-3232  
Steve Hibbard  
shibbard@newyorkbussales.com

ALL of our Service Updates can be found on the [New York Bus Sales website](#)  
Or at the [New York Head Mechanic website](#)

