

Service Manual

# NCL Century 2

Public Use Wheelchair Lifts

Lift Serial Numbers

**14123000001**

thru

**15041700144**

DOT — Public Use Lift

"DOT — Public Use Lift" verifies that this platform lift meets the "public use lift" requirements of FMVSS No. 403. This lift may be installed on all vehicles appropriate for the size and weight of the lift, but must be installed on buses, school buses, and multi-purpose passenger vehicles other than motor homes with a gross vehicle weight rating (GVWR) that exceeds 4,536 kg (10,000 lb).



631 West 11th Street, P.O. Box 310, Winamac, IN 46996, USA

Phone: 1-574-946-4139 • 1-800-THE-LIFT • [www.braunability.com](http://www.braunability.com)



# Warranty and Registration Instructions

Immediately upon receiving the lift, examine the unit for any damage. Notify the carrier at once with any claims.

Two warranty/registration cards (shown right) are located in the lift-mounted manual storage pouch. The sales representative must process one of the cards. The consumer must fill out the other card and mail it to BraunAbility®. The warranty is provided in this manual. The warranty cards must be processed to activate the warranty.

Model No.      Serial No.

OWNER'S WARRANTY REGISTRATION	
XXXXXXXXXX	XX-XXXXXX
PURCHASED FROM _____	
OWNER	
NAME _____	DATE INSTALLED _____
ADDRESS _____	
CITY _____	
TELEPHONE _____	STATE _____ ZIP _____
TO VALIDATE WARRANTY REGISTRATION CARDS MUST BE RETURNED TO THE BRAUN CORPORATION.	

Sample Warranty/Registration Card

Two BraunAbility® Serial No. identification tags (shown below) are posted on the lift. One I.D. tag is posted on the opposite pump side vertical arm. A second I.D. tag is located on the opposite pump side tower. Both I.D. tags provide the product identification information provided on the

warranty/registration card. Record the information in the space provided (or document on a copy). This information must be provided when filing a warranty claim or ordering parts.

BraunAbility® INDIANA, USA BRAUNABILITY.COM®	
XXXX Use Lift	
MODEL NUMBER	_____
XXXXXXXXXX	→ Model No. _____
Max. Lifting Capacity - XXXlb	
SERIAL NUMBER	_____
XXXXXXXXXXXX	→ Serial No. _____
MFG DATE	_____
XX/XX/XXXX	→ Date of Manufacture _____
CE	

Sample Serial Number Identification Tag

# Contents

## Troubleshooting and Maintenance

Lift Terminology.....	2
Switch and Sensor Locations .....	3
Certification Checklist Diagnostic Procedures.....	4
Platform Fold Pressure Adjustment.....	5
Platform Angle Adjustment .....	6-7
Platform Stop Blocks .....	7
Tower Microswitch Adjustment .....	8
Lubrication Diagram .....	10
Maintenance and Lubrication Schedule.....	11-14
Lift Electrical Schematic .....	15
Lift Wiring Diagram .....	16

## Hydraulics

Hydraulic Schematic .....	17
Hydraulics Parts List .....	18
Hydraulics Diagram .....	19

## Repair Parts

### Pump Module

Pump Module Parts List .....	20
Pump Module Diagram .....	21

### Lift Exploded Views and Parts Lists

Base Plate Assembly .....	22-25
Top Parallel Arm Assembly.....	26
Bottom Parallel Arm Assembly.....	27
Hydraulic Cylinder Assembly - Main.....	28
Vertical Arm Assembly.....	29
Arm Cover Assembly.....	30
Handrail Assembly .....	31
Platform Assembly.....	32-35

## Warranty

BraunAbility® Limited Warranty.....	36-38
-------------------------------------	-------

# Lift Terminology

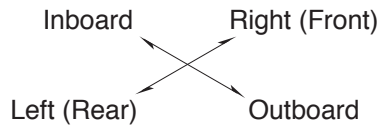
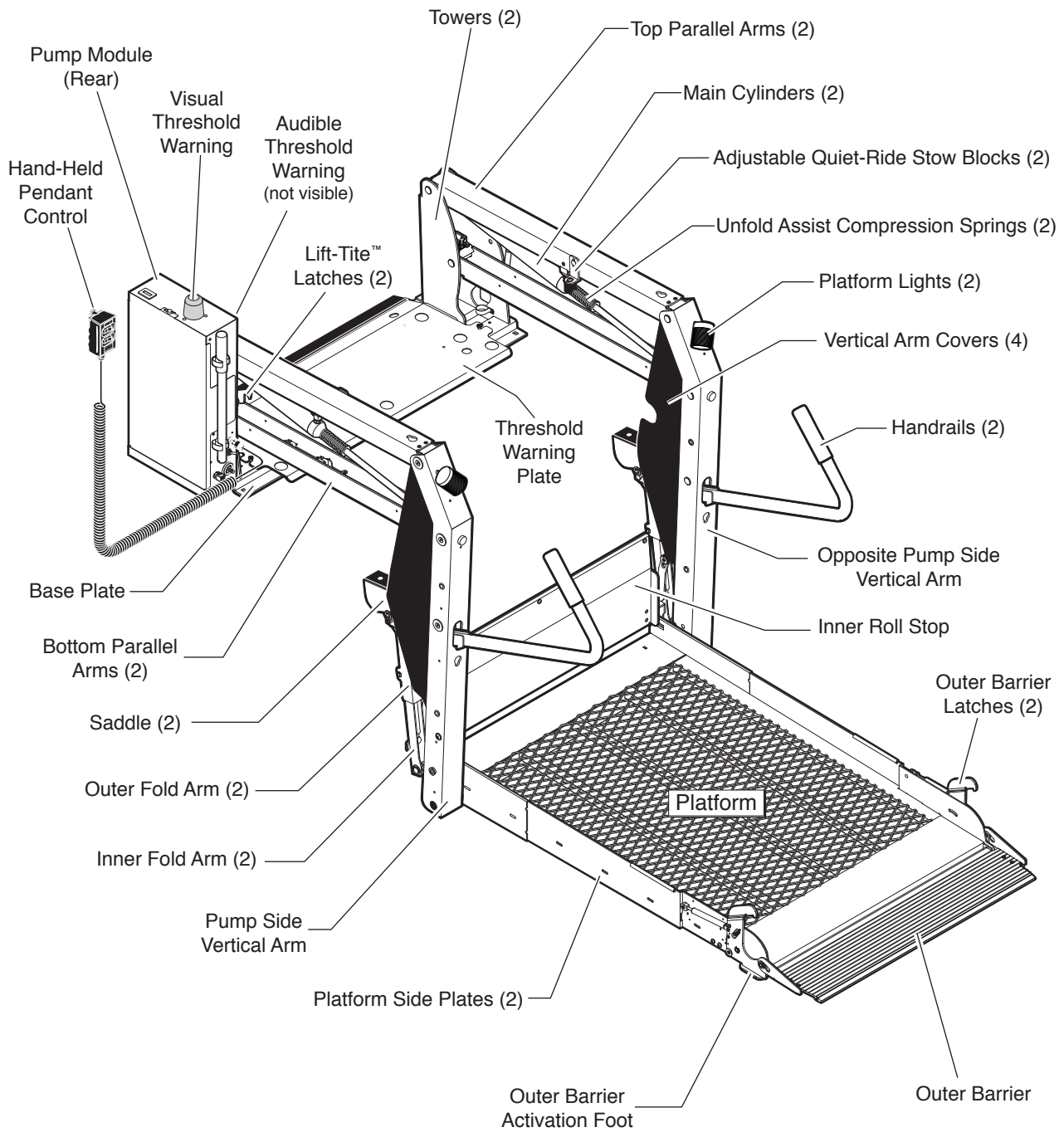

# Switch and Sensor Locations

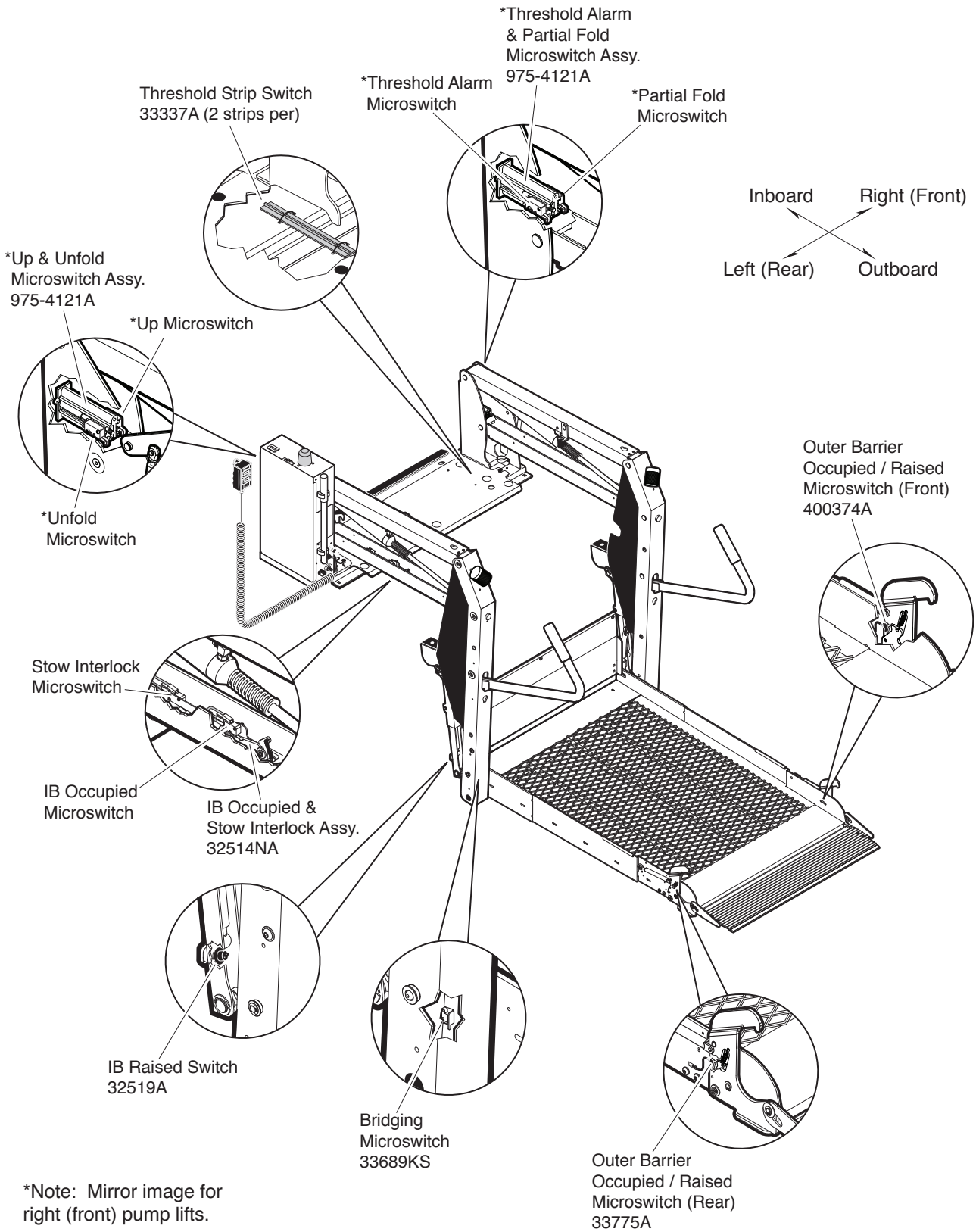

## Certification Checklist Diagnostic Procedures

The following operations and conditions must be functionally verified in order for the lift to be FMVSS 403/404 compliant. If an operation does not function as described or a condition is not met, follow the referenced procedures to correct the problem or contact BraunAbility Aftersales.

- Vehicle movement is prevented unless the lift door is closed, ensuring the lift is stowed.
  1. Verify on the pump module mounted interlock connector that the lift stowed signal - pin 9 has a ground signal OR lift not stowed signal - pin 5 has an open signal (depends on interlock used).
  2. Refer to the interlock installation instructions.
  
- Lift operation shall be prevented unless the vehicle is stopped and vehicle movement is prevented.
  1. Verify vehicle secure signal (pin 6) has a +12 volt signal.
  2. Refer to the interlock installation instructions.
  
- The platform will not fold/stow if occupied.
  - Refer to Platform Fold Pressure Adjustment procedures.
  
- The inner roll stop will not raise if occupied.
  - Call BraunAbility Aftersales.
  
- The outer barrier will not raise if occupied.
  - Refer to Outer Barrier Fold Pressure Adjustment procedures.
  
- Verify platform lighting when lift is deployed and pendant illumination when lift is powered.
  1. Replace bulb(s) in the light housing.
  
- A warning will activate if the threshold area is occupied when the platform is at least 1" below floor level.
  1. Remove the threshold warning plate.
  2. Verify the threshold strip switch connector is securely connected.
  3. Reinstall threshold warning plate.
  4. Test threshold warning (push down on plate). If warning is not activated, see Step 5.
  5. Remove the threshold warning plate and replace non-functioning threshold switch.
  6. Repeat Step 4. If warning is still not activated, call BraunAbility Aftersales.
  
- Platform movement is prohibited beyond the position where the inner roll stop is fully deployed (up).
  - Call BraunAbility Aftersales.
  
- Platform movement shall be interrupted unless the outer barrier is deployed (up).
  - Call BraunAbility Aftersales.

## Platform Fold Pressure Adjustment

1. Position the platform at the floor level loading position.
2. Loosen the hex nut on the adjustment screw (do not remove hex nut).
3. Turn the adjustment screw counter clockwise until the platform does not fold when the Fold button is pressed.
4. Turn the adjustment screw clockwise in 1/4 turn increments and press the Fold button until the platform folds completely. Note: Return the platform to floor level position after each attempt to fold the platform.
5. Turn the adjustment screw an additional 1/8 turn after the platform folds successfully.
6. Tighten the hex nut without moving the adjustment screw.
7. Verify the platform will not stow while occupied.

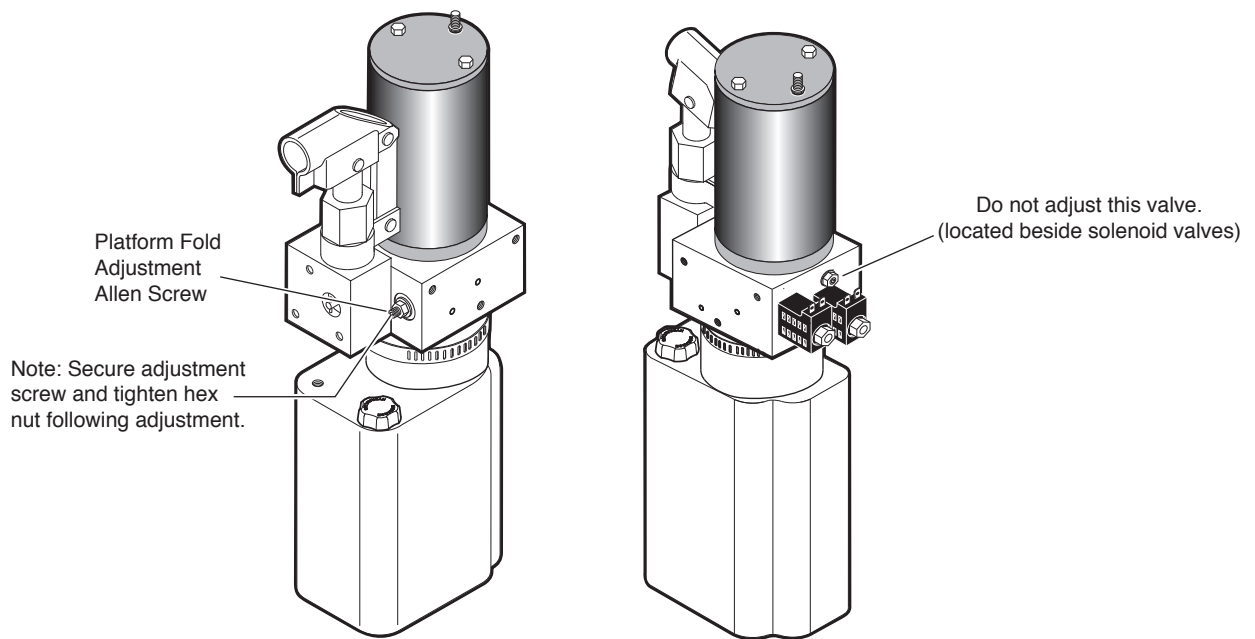

# Platform Angle Adjustment

## Lowering Sequence Requirements

1. The outboard end (toe) of the platform must contact the ground first to ensure the spring-loaded outer barrier unfolds fully. See Figure A.

2. The inboard end (heel) of the platform must lower fully (vertical arms must contact ground when fully lowered). See Figure A.

The angle of the platform at ground level directly affects the angle of the platform when positioned at floor level.

Raise the platform to floor level. Note the angle of the platform.

The platform at floor level should have a slight upward angle as shown in Figure B.

Adjust platform angle as detailed below.

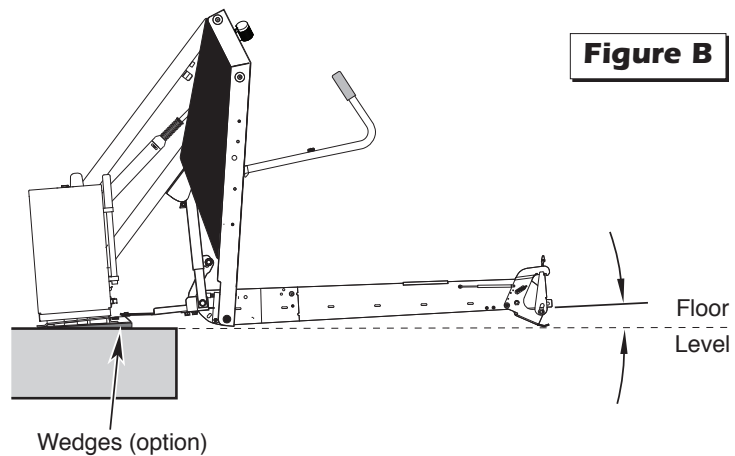
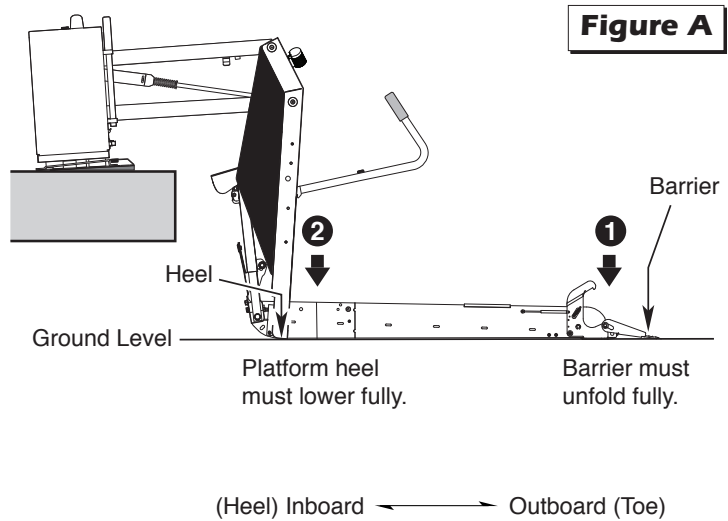

## Adjustment Procedure:

Platform angle adjustment Allen screws are provided on each side of the platform (see photo at right and details on following page).

Turn adjustment screws clockwise to raise the outboard end of the platform. Turn adjustment screws counterclockwise to lower the outboard end of the platform.

Both adjustment screws must be adjusted equally. Apply Loctite® to adjustment screws following adjustment.

**Platform Stop Blocks:** When adjusting platform angle, ensure both stop blocks are making full contact with the vertical arms (see photo at right and details on following page).

**Floor Level Adjustment:** Following platform angle adjustment, set platform floor level positioning as detailed in Tower Microswitch Adjustment.

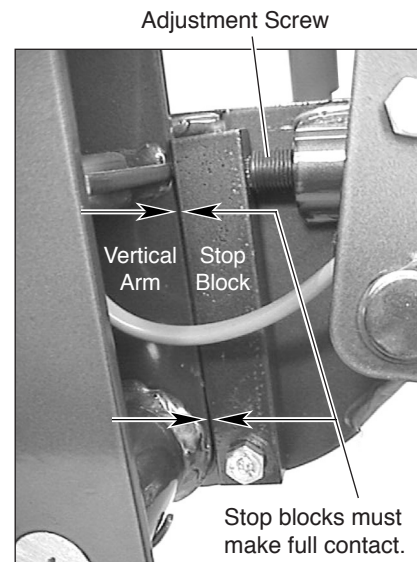



## Platform Angle Adjustment

Adjustment Allen screws are provided on each side of the lift platform for adjusting the platform angle. Adjust platform angle as specified on previous page.

To raise the outboard end of platform - turn adjustment screw clockwise.

To lower the outboard end of platform - turn adjustment screw counterclockwise.

Note: Both adjustment screws must be adjusted equally.

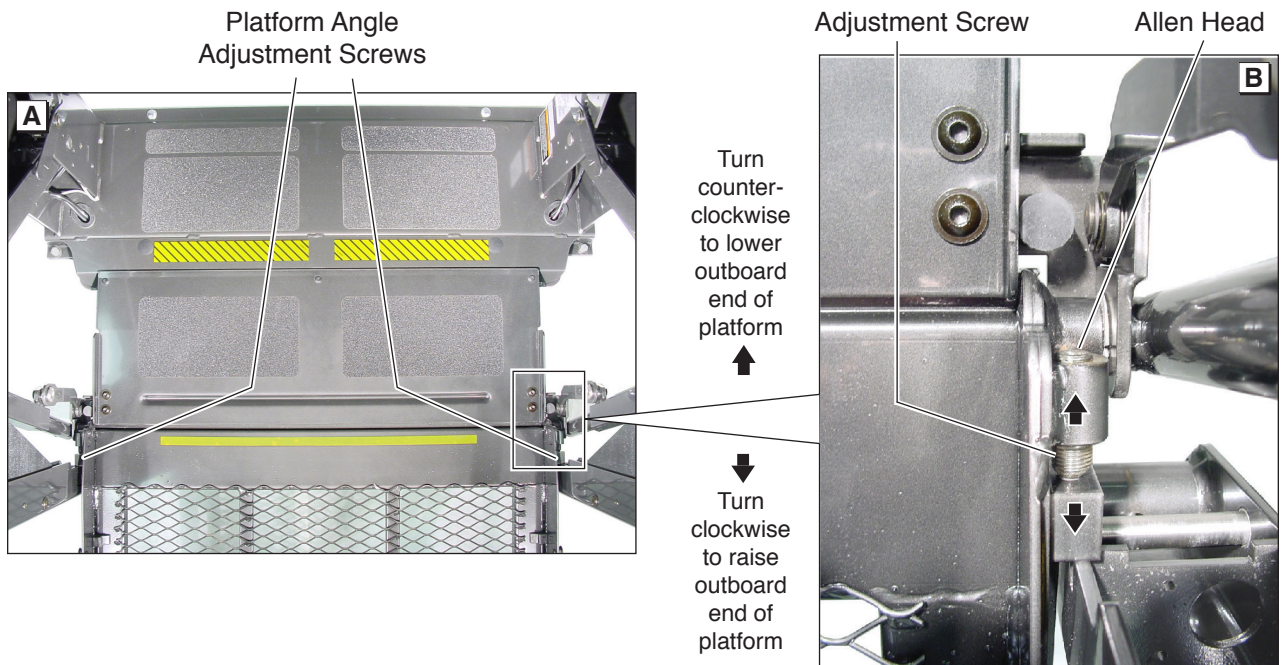

## Platform Stop Blocks

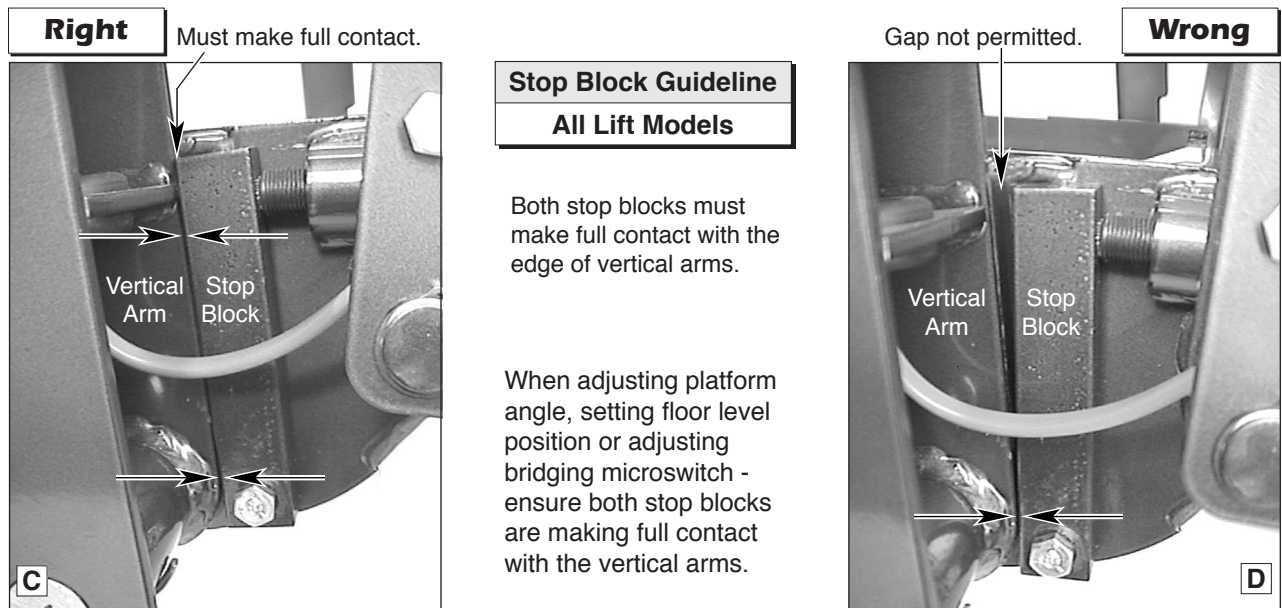

## Tower Microswitch Adjustment

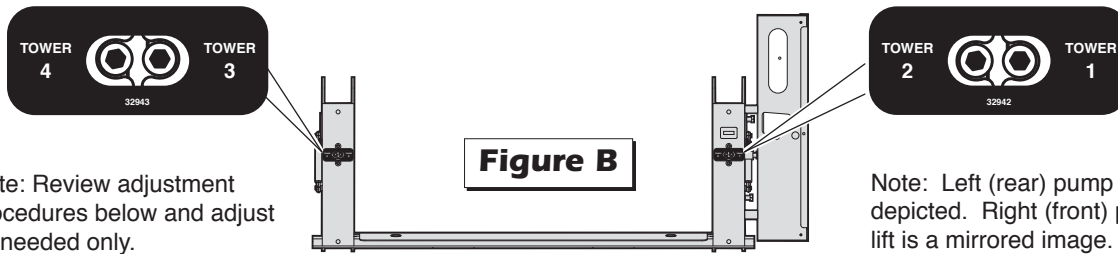

Note: Review adjustment procedures below and adjust as needed only.

Note: Left (rear) pump lift depicted. Right (front) pump lift is a mirrored image.

### Tower 1 (Unfold) Switch Adjustment Floor Position from Stow

1. Position platform at the fully stowed position using the manual hand pump or pendant control.
2. Turn switch adjustment screw clockwise 3 full turns.
3. Press pendant UNFOLD switch (continue pressing switch until platform stops unfolding).
4. When platform stops unfolding, turn switch adjustment screw counterclockwise while pressing the pendant UNFOLD switch. Platform position will change. Repeat adjustment until criteria below is met.

#### Proper Adjustment Criteria:

- Bridge plate should just rest on threshold plate (base plate).
- Should be an approximate 1/8" clearance between outboard end of the saddle and the lower parallel arm. See Photo A.

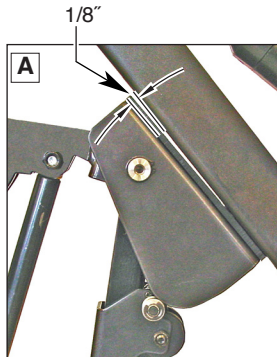

### Tower 2 (Up) Switch Adjustment Floor Position from Below Floor

1. Lower platform a minimum of 6" below floor level position using the manual hand pump or pendant control.
2. Turn switch adjustment screw counterclockwise 3 full turns.
3. Press pendant UP switch (continue pressing switch until platform stops).
4. When platform stops, turn switch adjustment screw clockwise while pressing the pendant UP switch. Platform position will change. Adjust platform to meet criteria listed for Tower 1 Switch "Proper Adjustment Criteria".

Radius of Tower 4 Microswitch Blade activated by Apex of Activation Plate.

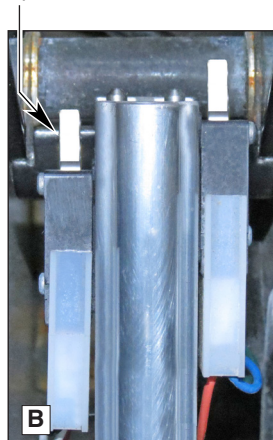

### Tower 3 (Alarm) Switch Adjustment Threshold Alarm Switch

1. Position platform at the fully raised (floor level) position using the pendant control.
2. Place pressure on the threshold warning plate (base plate). Continue applying pressure to threshold plate and turn switch adjustment screw clockwise until alarm sounds. If alarm sounds when pressure is first applied go to Step 3.
3. Continue applying pressure to threshold plate and slowly turn switch adjustment screw counterclockwise until the alarm stops sounding.

### Tower 4 (Fold) Switch Adjustment Partial Fold Switch

1. Position platform at 45° angle using the manual hand pump or pendant control.
2. View the Tower 4 microswitch inside the lift tower (see Photo B). Turn the switch adjustment screw in or out as needed until the radius of the microswitch blade rides on the apex of the activation plate.
3. Verify proper adjustment. Criteria below must be met.

#### Proper Adjustment Criteria:

- Apply pressure (push down) on outboard end of platform by pressing the hand pendant FOLD switch. The platform should not fold (stow) with light pressure applied.
- When folding fully, the platform should stow tightly (snug with stow blocks).

## **NOTES**

This page intentionally left blank.

# Maintenance and Lubrication

## Lubrication Diagram

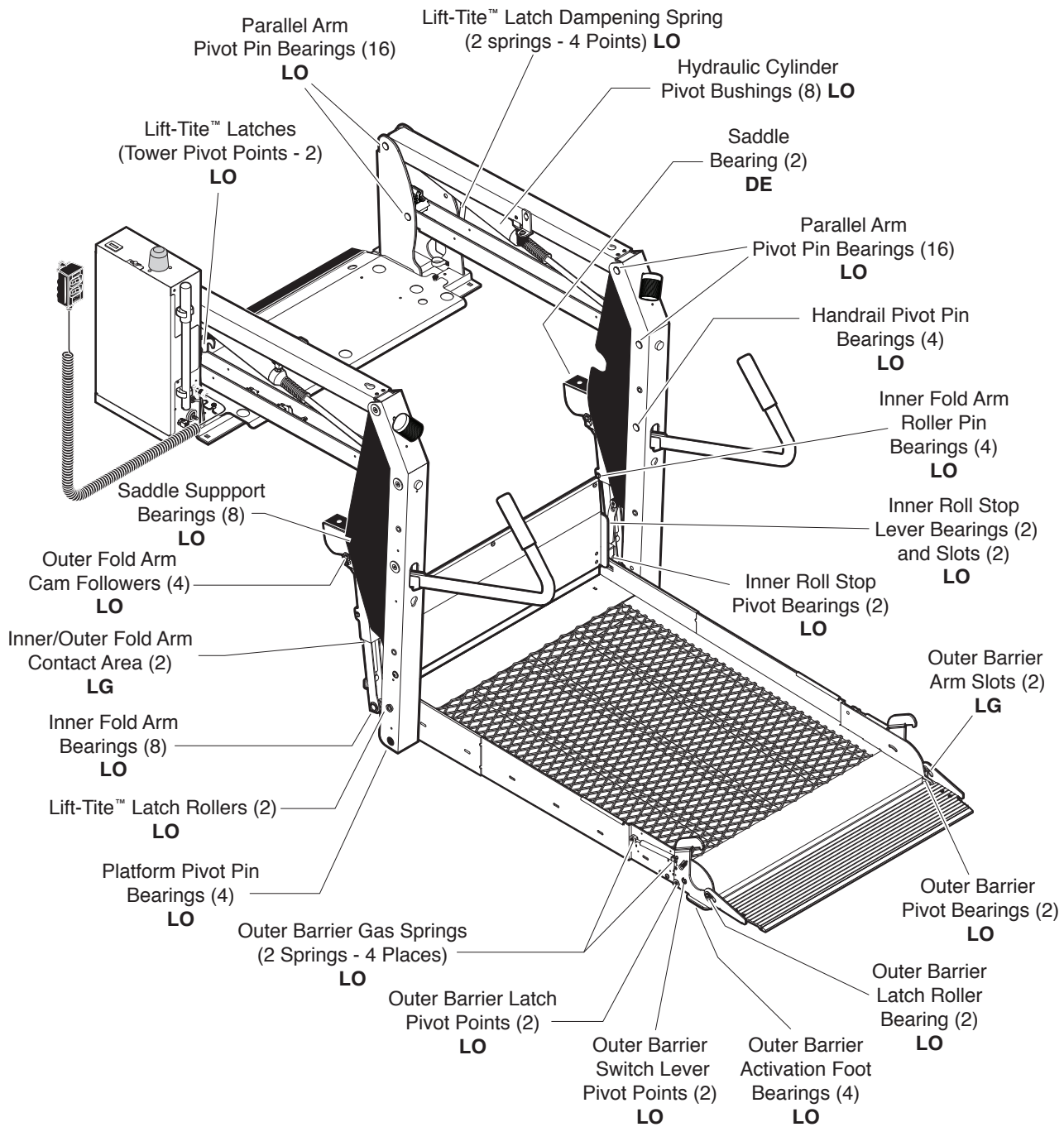

See the Maintenance/Lubrication Schedule for recommended applications per number of cycles.

Lubricant	Type	Specified (recommended) Lubricant	Available Amount	BraunAbility Part No.
<b>LO - Light Oil</b>	Light Penetrating Oil (30 Weight or equivalent)	LPS2, General Purpose Penetrating Oil	16 oz. Aerosol Can	15807
<b>DE - Door-Ease</b>	Stainless Stick Style (tube)	Door-Ease Stick (tube)	1.68 oz.	15806
<b>LG - Light Grease</b>	Light Grease (Multipurpose)	Lubriplate	14 oz. Can	15805



## Maintenance and Lubrication Schedule

Proper maintenance is necessary to ensure safe, troublefree operation. Inspecting the lift for any wear, damage or other abnormal conditions should be a part of the transit agency daily service program. Simple inspections can detect potential problems.

The maintenance and lubrication procedures specified in this schedule must be performed by a BraunAbility authorized service representative at the scheduled intervals according to the number of cycles.

BraunAbility dual parallel arm lifts are equipped with hardened pins and self-lubricating bushings to decrease wear, provide smooth operation and extend the service life of the lift.

When servicing the lift at the recommended intervals, inspection and lubrication procedures specified in the previous sections should be repeated. Clean components and the surrounding area before applying lubricants. Clean only with water, and then when cleaned, lubricate as directed in the lubrication diagram. Do not use solvents to clean.

LPS2 General Purpose Penetrating Oil is recommended where Light Oil is called out. Use of improper lubricants can attract dirt or other contaminants which could result in wear or damage to the components. Platform components exposed to contaminants when lowered to the ground may require extra attention.

Lift components requiring grease are lubricated during assembly procedures. When these components are replaced, grease must be applied during installation procedures. Specified lubricants are available

from BraunAbility (part numbers provided on previous page).

All listed inspection, lubrication and maintenance procedures should be repeated at 750 cycle intervals following the scheduled 4500 cycle maintenance procedures. These intervals are a general guideline for scheduling maintenance procedures and will vary according

to lift use and conditions. Lifts exposed to severe conditions (weather, environment, contamination, heavy usage, etc.) may require inspection and maintenance procedures to be performed more often than specified.

**Cycle Counter:** NCL-2 Series lift models are equipped with a cycle counter located on the top of the pump module. This cycle counter allows the lift attendant/operator to easily track the number of cycles during daily inspections of the lift.

Discontinue lift use immediately if maintenance and lubrication procedures are not properly performed, or if there is any sign of wear, damage or improper operation. Contact your sales representative or call BraunAbility at 1-800-946-7513. One of our Aftersales representatives will direct you to an authorized service technician who will inspect your lift.

**⚠ WARNING**

**Maintenance and lubrication procedures must be performed as specified by an authorized service technician. Failure to do so may result in serious bodily injury and/or property damage.**

<b>750 Cycles</b>	Outer barrier pivot points (2)	Apply Light Oil - See Lubrication Diagram
	Outer barrier latch pivot points (2)	Apply Light Oil - See Lubrication Diagram
	Outer barrier switch lever pivot points (2)	Apply Light Oil - See Lubrication Diagram
	Outer barrier latch roller bearing (2)	Apply Light Oil - See Lubrication Diagram
	Outer barrier arm slots (2)	Apply Light Grease - See Lubrication Diagram
	Outer barrier gas springs (2 springs - 4 points)	Apply Light Oil - See Lubrication Diagram
	Lift-Tite™ latches (tower pivot points - 2)	Apply Light Oil - See Lubrication Diagram
	Lift-Tite™ latch gas (dampening) spring pivot points (2 springs - 4 points)	Apply Light Oil - See Lubrication Diagram
	Inspect Lift-Tite™ latches and gas (dampening) springs for wear or damage (bent, deformed or misaligned), positive securement (lock nuts / external snap rings) and proper operation	Resecure, replace damaged parts or otherwise correct as needed. Note: Apply Light Grease to Lift-Tite™ latch tower pivot point if replacing latch.
	continued	Inspect outer barrier for proper operation

## Maintenance and Lubrication Schedule

<b>750 Cycles</b>	continued	Inspect outer barrier latch for proper operation, positive securement, and detached or missing spring(s)	Correct or replace damaged parts and/or relubricate. See Lubrication Diagram
		Adjust fold pressure	See Platform Fold Pressure Adjustment
		Verify FMVSS 403/404 Certification Checklist	See Certification Checklist Diagnostic Procedures
		Inspect lift for wear, damage or any abnormal condition	Correct as needed.
		Inspect lift for rattles	Correct as needed.

<b>1500 Cycles</b>	<b>Perform all procedures listed in previous section also</b>	
	Inner/outer fold arms (2)	Apply grease (synthetic) to contact areas between inner/outer fold arms. See Lubrication Diagram
	Platform pivot pin bearings (4)	Apply Light Oil - See Lubrication Diagram
	Inner fold arm bearings (8)	Apply Light Oil - See Lubrication Diagram
	Inner roll stop pivot bearings (2)	Apply Light Oil - See Lubrication Diagram
	Inner roll stop lever bearings (2)	Apply Light Oil - See Lubrication Diagram
	Inner roll stop lever slot (2)	Apply Light Oil - See Lubrication Diagram
	Saddle support bearings (8)	Apply Light Oil - See Lubrication Diagram
	Outer fold arm roller pin bearings (4)	Apply Light Oil - See Lubrication Diagram
	Outer fold arm cam followers (4)	Apply Light Oil - See Lubrication Diagram
	Parallel arm pivot pin bearings (16)	Apply Light Oil - See Lubrication Diagram
	Handrail pivot pin bearings (4)	Apply Light Oil - See Lubrication Diagram
	Hydraulic cylinder pivot bushings (8)	Apply Light Oil - See Lubrication Diagram
	Inspect Lift-Tite™ latch rollers for wear or damage, positive securement and proper operation (2)	Correct, replace damaged parts and/or relubricate. See Lubrication Diagram.
	Inspect inner roll stop for: • Wear or damage • Proper operation. Roll stop should just rest on top surface of the threshold plate. • Positive securement (both ends)	Resecure, replace or correct as needed. See Platform Angle Instructions and Tower Microswitch Adjustment Instructions.
	Inspect handrail components for wear or damage, and for proper operation	Replace damaged parts.
Inspect microswitches for securement and proper adjustment.	Resecure, replace or adjust as needed. See Microswitch Adjustment Instructions.	
Make sure lift operates smoothly	Realign towers and vertical arms. Lubricate or correct as needed.	
Inspect inner roll stop locks (2) and torsion springs (2) for wear or damage and for proper operation	Replace damaged parts. Apply Light Oil to inner roll stop lock pivot point.	
continued		

## Maintenance and Lubrication Schedule

<p>continued</p> <p><b>1500 Cycles</b></p>	<p>Inspect external snap rings:</p> <ul style="list-style-type: none"> <li>• Inner fold arms (6)</li> <li>• Lift-Tite™ latch rollers (2)</li> <li>• Lift-Tite™ latch gas (dampening) springs (4)</li> <li>• Outer barrier latch gas springs (2)</li> <li>• Outer barrier latch pivots (2)</li> <li>• Outer barrier switch lever pivots (2)</li> <li>• Outer barrier latch rollers (2)</li> <li>• Outer fold arm cam followers (4)</li> <li>• Outer fold arm roller pins (4)</li> <li>• Inner roll stop lever bracket pins (2)</li> <li>• Platform fold link (2)</li> </ul> <p>Inspect inner fold arm pins (2), axles (2) and bearings (8) for wear or damage and positive securement</p> <p>Remove pump module cover and inspect:</p> <ul style="list-style-type: none"> <li>• Hydraulic hoses, fittings and connections for wear or leaks</li> <li>• Harness cables, wires, terminals and connections for securement or damage</li> <li>• Relays, fuses, power switch and lights for securement or damage</li> </ul>	<p>Resecure or replace if needed.</p> <p>Replace damaged parts and resecure as needed. Apply Light Oil.</p> <p>Resecure, replace or correct as needed.</p>
<p><b>4500 Cycles</b></p> <p>continued</p>	<p style="border: 1px solid black; padding: 2px; text-align: center;"><b>Perform all procedures listed in previous section also</b></p> <p>Inspect cotter pins on platform pivot pin (2)</p> <p>Hydraulic Fluid (Pump) - Check level. Note: Fluid should be changed if there is visible contamination. Inspect the hydraulic system (cylinder, hoses, fittings, seals, etc.) for leaks if fluid level is low.</p> <p>Inspect cylinders, fittings and hydraulic connections for wear, damage or leaks</p> <p>Inspect parallel arms, bearings and pivot pins for visible wear or damage</p> <p>Inspect parallel arm pivot pin mounting bolts (8)</p> <p>Inspect platform pivot pins, bearings and vertical arms for wear, damage and positive securement</p> <p>Inspect inner/outer fold arms, saddle, saddle support and associated pivot pins and bearings for visible wear or damage</p> <p>Inspect gas springs (cylinders - 6) for wear or damage, proper operation and positive securement</p> <p>Inspect saddle bearing (UHMW - 2)</p> <p>Inspect vertical arm plastic covers</p>	<p>Resecure, replace or correct as needed</p> <p>Use BraunAbility 32840-QT (Exxon® Univis HVI 26). Do not mix with Dextron III or other hydraulic fluids. Check fluid level with platform lowered fully. Fill to maximum fluid level indicated on reservoir (specified on decal). Do not overfill. If fluid level decal is not present - measure 1-3/8" from the fill port to locate fluid level.</p> <p>Tighten, repair or replace if needed.</p> <p>Replace if needed.</p> <p>Tighten or replace if needed.</p> <p>Replace damaged parts and resecure as needed. Apply Light Grease during reassembly procedures.</p> <p>Replace if needed.</p> <p>Tighten, replace or correct as needed</p> <p>Apply Door-Ease or replace if needed. See Lubrication Diagram.</p> <p>Resecure or replace if needed.</p>

## Maintenance and Lubrication Schedule

<p>continued</p> <p><b>4500 Cycles</b></p>	<p>Inspect power cable</p> <p>Mounting</p> <p>Decals and Antiskid</p>	<p>Resecure, repair or replace if needed.</p> <p>Check to see that the lift is securely anchored to the vehicle and there are no loose bolts, broken welds, or stress fractures.</p> <p>Replace decals if worn, missing or illegible. Replace antiskid if worn or missing.</p>
<p><b>Consecutive 750 Cycle Intervals</b></p>	<p>Repeat all previously listed inspection, lubrication and maintenance procedures at 750 cycle intervals.</p>	
<p><b>Lift Disposal Procedure</b></p>	<p>No lift components contain unacceptable amounts of lead, cadmium, mercury, or hexavalent chromium.</p> <ol style="list-style-type: none"> <li>1. Lower platform to ground.</li> <li>2. Open pump module manual relief valve.</li> <li>3. Disconnect power from lift.</li> <li>4. Capture and recycle hydraulic fluid.</li> <li>5. Disassemble lift and recycle components.</li> </ol> <p>Refer to exploded views in appropriate service manual.</p>	



# Lift Electrical Schematic

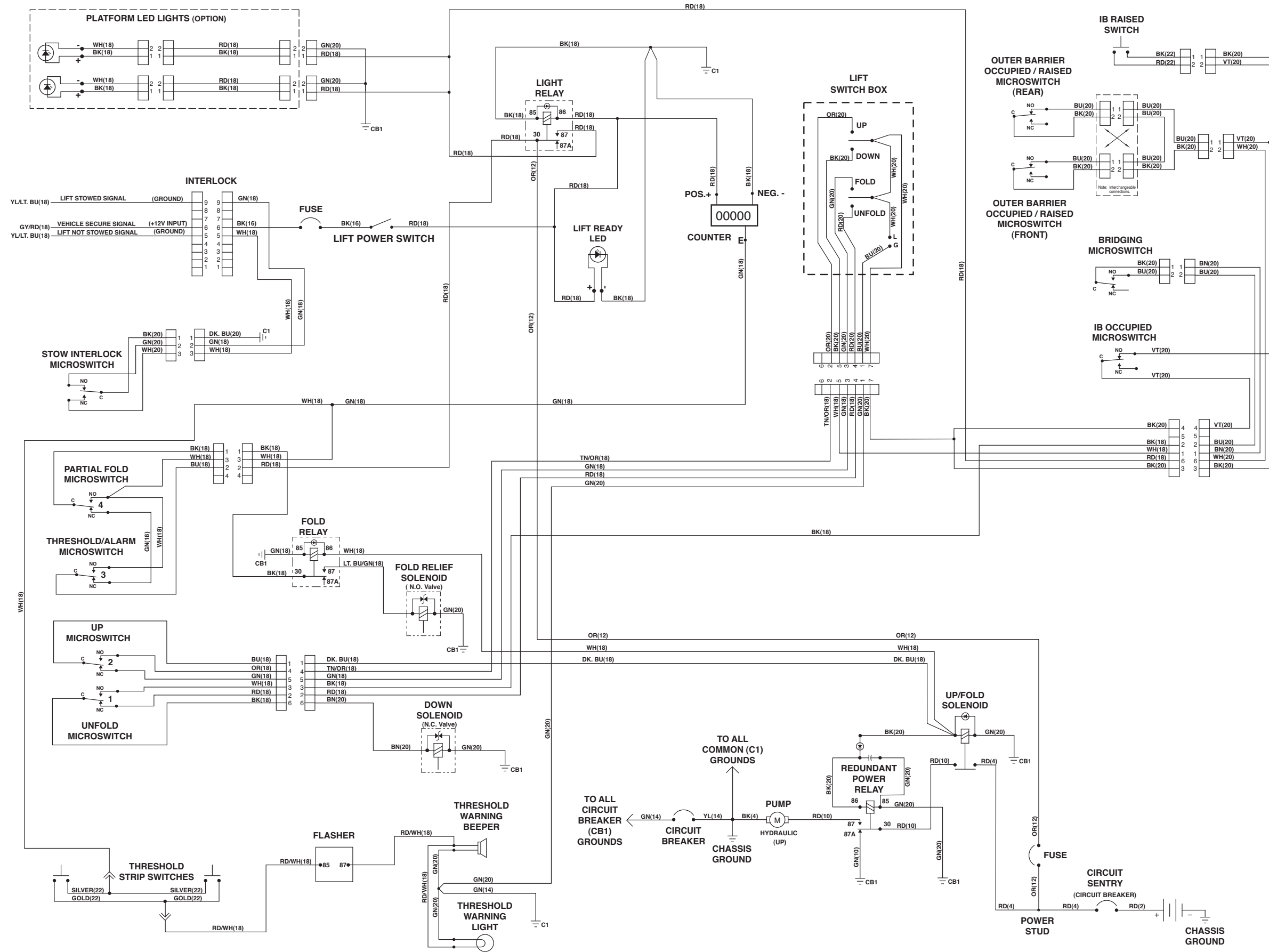

DESCRIPTION	SYMBOL
CAPACITOR	
MICROSWITCH	
DIODE	
FLASHER	
COUNTER	
RELAY	
LIGHT	
BEEPER	
BATTERY	
CHASSIS GROUND	
CIRCUIT BREAKER/FUSE	
JUNCTION	
MOTOR	
SOLENOID WITH SUPPRESSION	
SWITCH	
CONNECTER	

**NOTES:**  
 1) JUNCTIONS ONLY OCCUR AT MARKED INTERSECTIONS.

Unfold for:  
Lift Electrical  
Schematic

# Lift Wiring Diagram

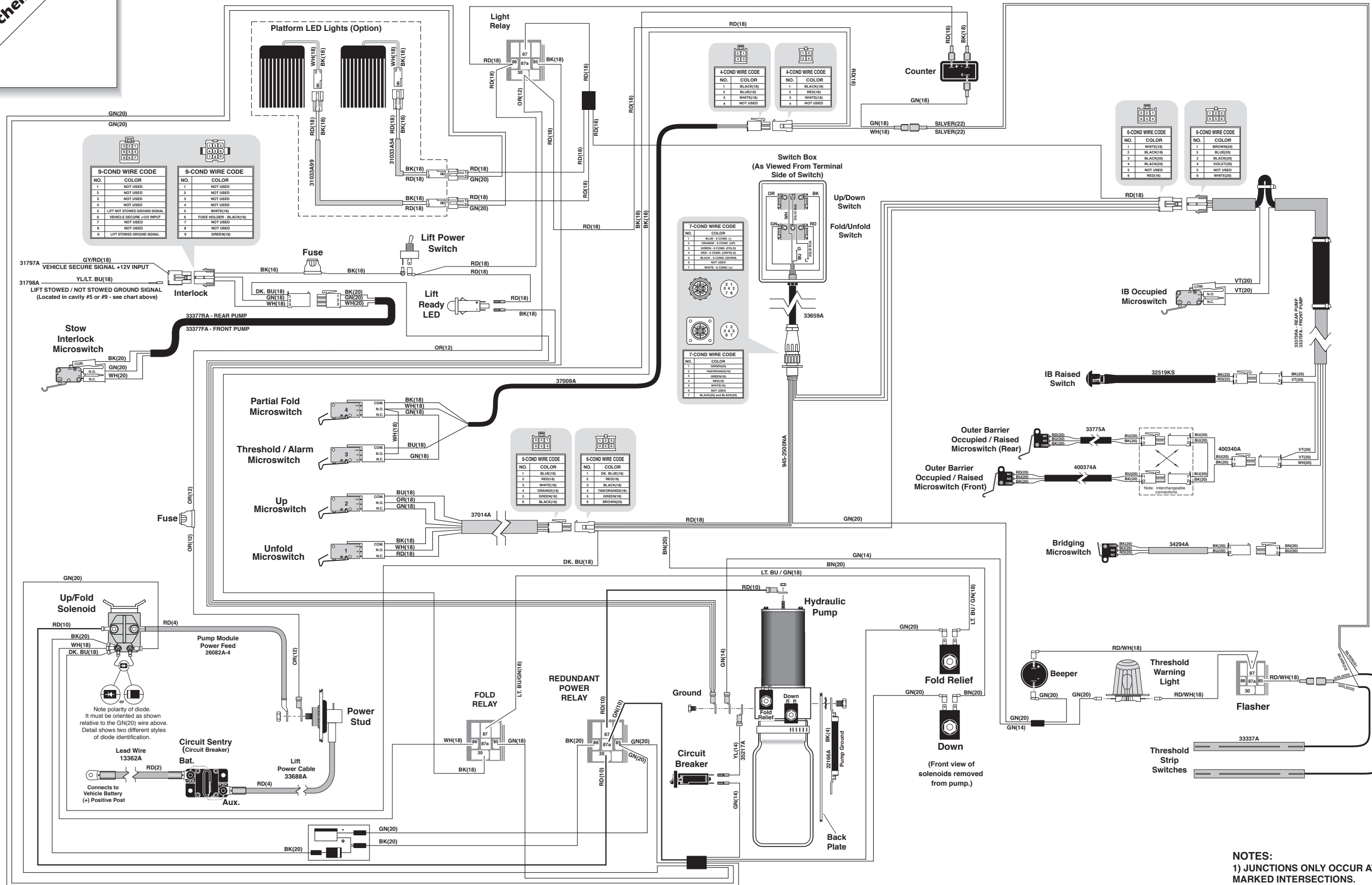

NOTES:  
1) JUNCTIONS ONLY OCCUR AT MARKED INTERSECTIONS.

# Hydraulic Schematic

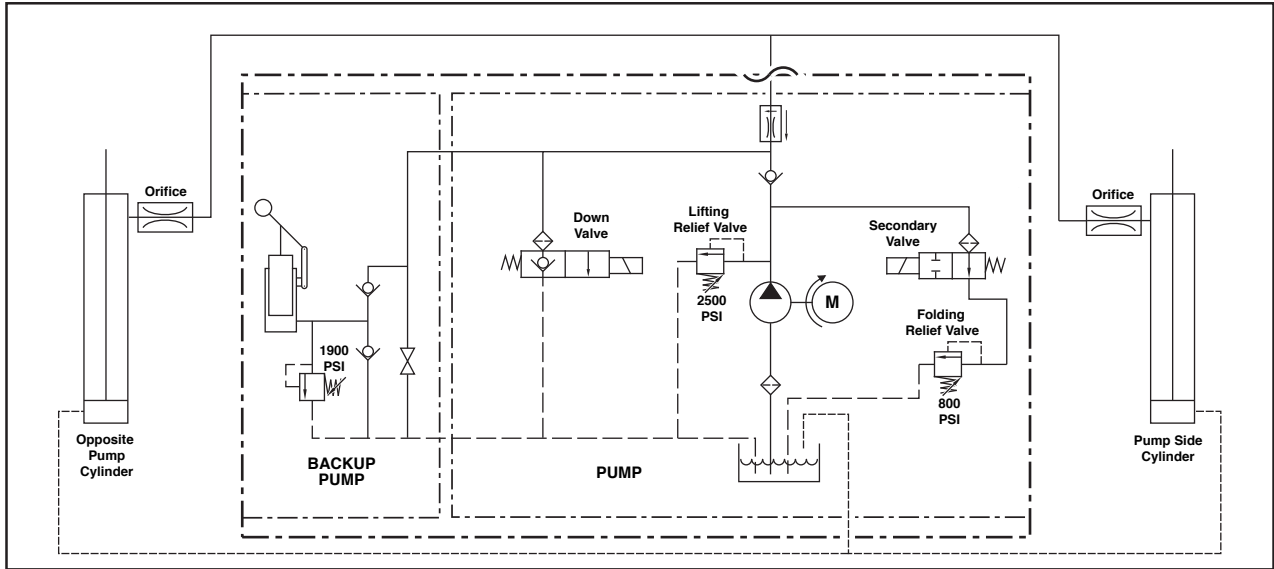

Description	Symbol	Description	Symbol
Fixed Displacement Pump		Hydraulic Port	
Pump Motor		2 Way 2 Position Solenoid Valve	
Backup Pump		Pressure Compensated Flow Control	
Single Acting Cylinder		Relief Valve	
Check Valve		Filter Screen	
Unfold Orifice		Vented Reservoir	
Manual Shutoff Valve			

## Hydraulics Parts List

Item	Qty.	Description	Part #
1	1	Pump Assembly (M-268-0114) 120G / 12V / Dual Relief	32858-12V
2	1	Solenoid, 4-Post Trombetta - Angle	35310
3	1	Motor, Pump - 12 Volt - Low RPM	29690
4	1	Valve Assembly, "Dual Relief" (complete)	31120K
5	1	Cartridge (only), "Dual Relief" Valve - (shown below)	31121
6	2	Coil w/Suppression (only) - (shown below)	400783
7	1	Valve Assembly, "Down" (complete)	31348K
8	1	Cartridge (only), "Down" Valve - (shown below)	26078
9	3	Screw, 1/4-20 x 2-1/4", Allen Head	26080
10	1	Hand Pump (Backup) with O-Rings (Item 11)	26074
11	4	O-Ring (only), Hand Pump Mounting	17351
12	1	Clamp, Reservoir - H-48 (M259)	17069
13	1	Reservoir, Hydraulic Fluid	30160
14	1	Cap, Reservoir Filler - Screw On	30167
15	1	Fitting, 90° - 1/8" NPT x 1/8" Barb - Plastic	87563
16	1	Clamp, Hose - Solenoid Mounting	29663
17	1	Hose, Thermal Plastic - Black, 1/8" I.D.	23742R* (6")
18	1	Handle with Grip	17206A
19	1	Fitting, Male 7-16-20 SAE O-Ring to Male 7/16-20 JIC 37°	24504
20	1	Elbow, 7/16-20 JIC 37 Female Swivel (1) - 7/16-20 JIC 37° Male (2)	26579
21	1	Hose Assembly, 1/8" (Opposite-Pump-Side)	16004A-086
22	1	Hose Assembly, 1/8" (Pump-Side)	16004A-046
23	2	Elbow, 90°, 7/16-20 SAE O-Ring Male - 7/16-20 JIC 37° Male, Orifice	26667
24	2	Cylinder ✓	C1514.3-0408N
25	2	Elbow, 90°, 1/4 NPT Male to 1/4" Barbed	15150
26	1	Hose, Thermal Plastic - Black, 1/8" I.D.	23742R* (68")
27	1	Hose, Thermal Plastic - Black, 1/8" I.D.	23742R* (30")
28	1	Diode Assembly, Up Solenoid	73906A
29	1	Kit, Hydraulic Port Service Cap	27049K
30	1	Connector, Plastic "Y", 1/8" O.D.	18877

- ✓ **Seal Kits:** If repairing a cylinder, order Seal Kit #1500-0500P.
- \* Raw material items ordered and priced per inch (order specified length).

**Hydraulic Fluid**

When adding or changing hydraulic fluid, use BraunAbility 32840-QT (Exxon® Unisvis HVI 26) hydraulic fluid (do not mix with Dextron III or other hydraulic fluids).

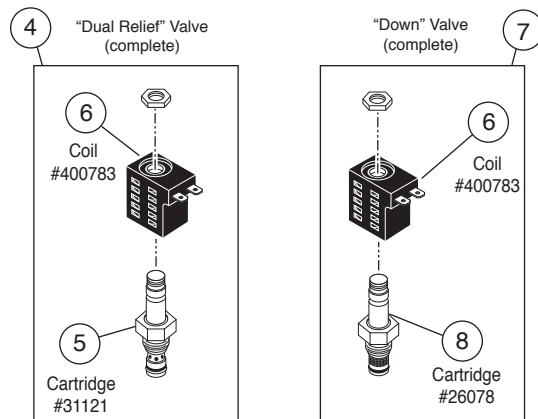

# Hydraulics Diagram

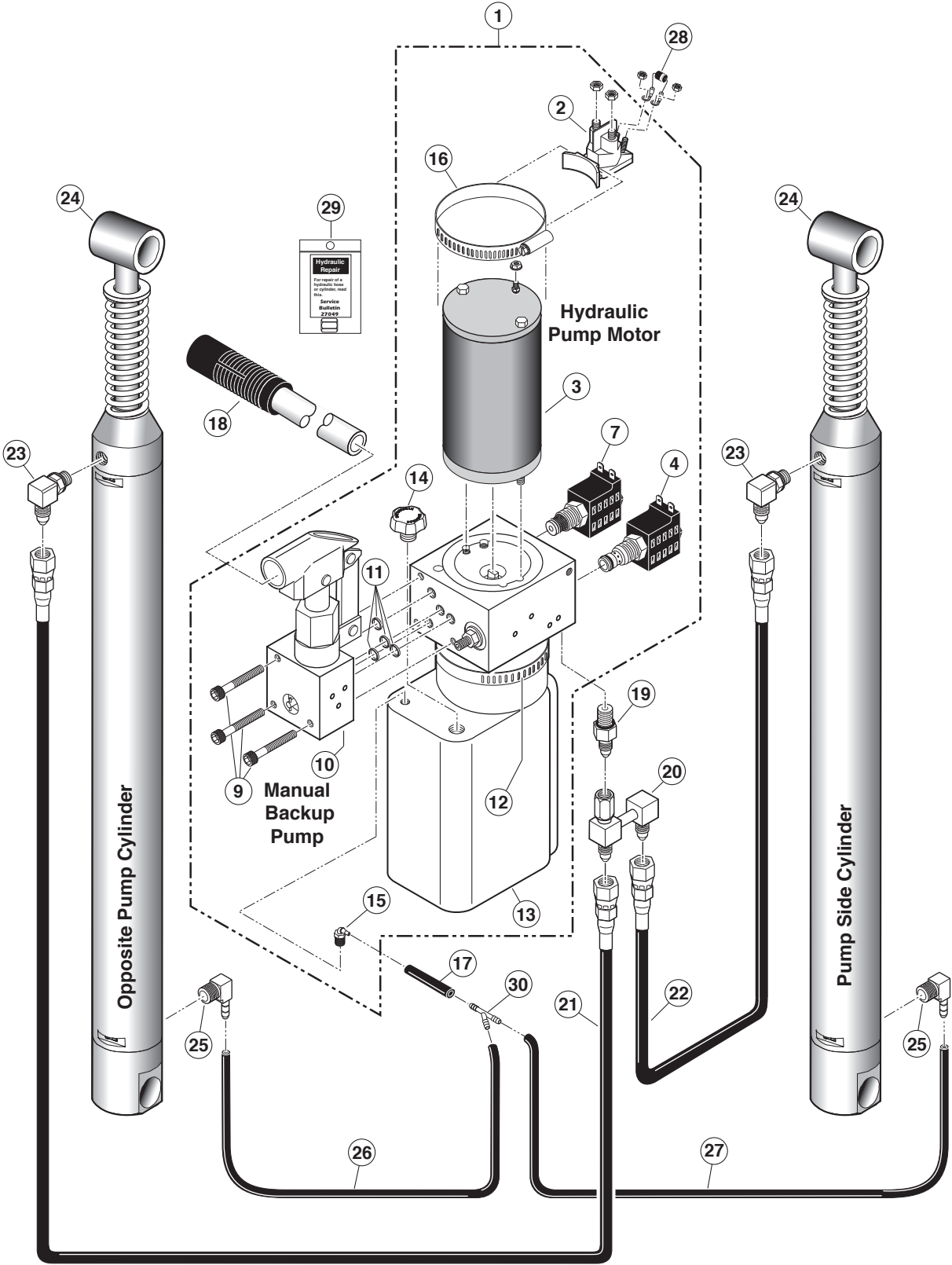

## Pump Module Parts List

Item	Qty.	Description	Right (Front)	Left (Rear)
			Pump Modules	Pump Modules
	1	Pump Module (complete), 12 Volt, Rear	945-5516FNA	945-5516RNA
1	1	Pump Assembly (M268-0114) 12V-120G - Dual Relief (Includes Items 1,2 & 20)	32858-12V	32858-12V
2	1	Solenoid, Up - 4-Post Trombetta - Angle	35310	35310
3	1	Housing, Pump (Complete Assembly 947-2513RNA (Rear) or 947-2513FNA (Front) Includes Items 3 - 21)	947-2513FNBM	947-2513RNBM
4	1	Beeper, Constant - High Output	33251	33251
5	1	Switch, Toggle w/ Gold Contacts	31787	31787
6	1	Stud, Power Feed	26084	26084
7	1	Lens, Threshold Warning - Red	30704	30704
8	1	Spacer, Lens - NHTSA	31386	31386
9	1	Metal Ring Base - Lamp	30971	30971
10	1	Socket, Lamp	30703	30703
11	3	Screw, #8-32 x 1/2" Pan Head Phillips - Thread Cut	30974	30974
12	1	Bulb, Light	19841	19841
13	2	Clamp, Spring - Pump Handle	12350	12350
14	4	Rivet, Pop, SD43BS - 1/8" - .13"/.19"	12954	12954
15	2	Rivet, Pop, SD62BS - 3/16" - .06"/.13"	11512	11512
16	1	Screw, T-Head, 10-32 x 3/8", Thumb	33435	33435
17	4	Rivet, Lock, Black, .22" x .11"/.15"	38456	38456
18	1	Diode, Green LED - Panel Mount	29545	29545
19	1	Circuit Breaker, Manual Reset - 15 Amps	35143	35143
20	1	Clamp, Hose - Solenoid Mounting	29663	29663
21	1	Harness, Lift Power ✓ See note below	33688A	33688A
22	1	Elbow, Female Swivel 7/16-20 JIC 37° to (2) Male 7/16-20 JIC 37°	26579	26579
23	4	Rivet, Snap, .122" Dia. - .158 - .197" Thick	25759	25759
24	4	Washer, 5/16" External Tooth	16368	16368
25	2	Bolt, 5/16-18 x 3/4", Nylock, Hex * See note below	29608	29608
26	2	Bolt, 5/16-18 x 1/2", Nylock, Hex * See note below	10012	10012
27	1	Cover, Pump Module	947-2519FNBM	947-2519RNBM
28	1	Pump Handle with Grip	17206A	17206A
29	1	Cycle Counter, LCD w/o Reset	30547	30547
30	1	Flasher, 12V	32461	32461
31	2	Relay, 30/40A SPDT 12V with Internal Diode	35249	35249
32	1	Diode Assembly, Up Solenoid	73906A	73906A
33	1	Cable, Pump Module Power	26082A-4	26082A-4
34	1	Harness, Main	945-2500NA	945-2500NA
35	1	Fitting, Male 7/16-20 O-Ring to Male 7/16-20 JIC 37°	24504	24504
36	1	Cable, Lift / Chassis Ground	22166A	22166A
37	1	Wire Assembly, Lift Interlock Connection	31797A	31797A
38	1	Wire Assembly, Lift Stowed Connection ✓ See note below	31798A	31798A
39	1	Rubber Boot, Red ✓ See note below	82046	82046
40	1	Control, Hand Pendant Assembly - Non Electronic / Non Shielded - Coiled ✓ See note below	33659A	33659A
41	1	Harness, Tower / Opposite Platform (Not shown - see Wiring Diagram)	37009A	37009A
42	1	Harness, Bridge Inputs - Platform (Not shown - see Wiring Diagram)	33373FA	33373RA
43	1	Harness, Stow - Platform (Not shown - see Wiring Diagram)	33377FA	33377RA
44	1	Harness, Tower / Pump - Platform (Not shown - see Wiring Diagram)	37014A	37014A
45	1	Harness, Extension Lighting - 54" (Not shown - see Wiring Diagram)	31033A54	31033A54
46	1	Harness, Extension Lighting - 99" (Not shown - see Wiring Diagram)	31033A99	31033A99
47	1	Hose Assembly, 86" - 1/8" Dia. - Swivel Ends (Not shown - see Hydraulic Diagram)	16004A-086	16004A-086
48	1	Hose Assembly, 46" - 1/8" Dia. - Swivel Ends (Not shown - see Hydraulic Diagram)	16004A-046	16004A-046
49	1	Hose, 1/8" Thermal Plastic (Not shown - see Hydraulic Diagram)	23742R	23742R
50	1	Connector, Plastic Y-1/8" OD	18877	18877
51	1	Kit, Hydraulic Port Service Cap (Not shown - see Hydraulic Diagram)	27049K	27049K
52	1	Decal, Warning / Pressure Relief Valve (Not shown) ✓ See note below	22249	22249
53	1	Decal, Lift Power - On/Off (Not shown) ✓ See note below	21494	21494
54	1	Decal, Dual Relief Valve Adjustment (Not shown) ✓ See note below	32201	32201
55	1	Decal, Manual Instructions - Public (Not shown) ✓ See note below	32940	32940

\* Apply Loctite® Threadlocker Red 271™ or equivalent to the three pump mounting bolts (items 25 and 26) if a blue nylon patch is not present on the bolts when retrofitting an M268-0114 pump assembly.

✓ Indicates items available for replacement part purposes only. These items are not included with replacement pump modules.

# Pump Module Diagram

## Pump Mounting Bolts

Apply Loctite®Threadlocker Red 271™ or equivalent to the three pump mounting bolts (items 25 and 26) if a blue nylon patch is not present on the bolts when retrofitting an M268 pump assembly.

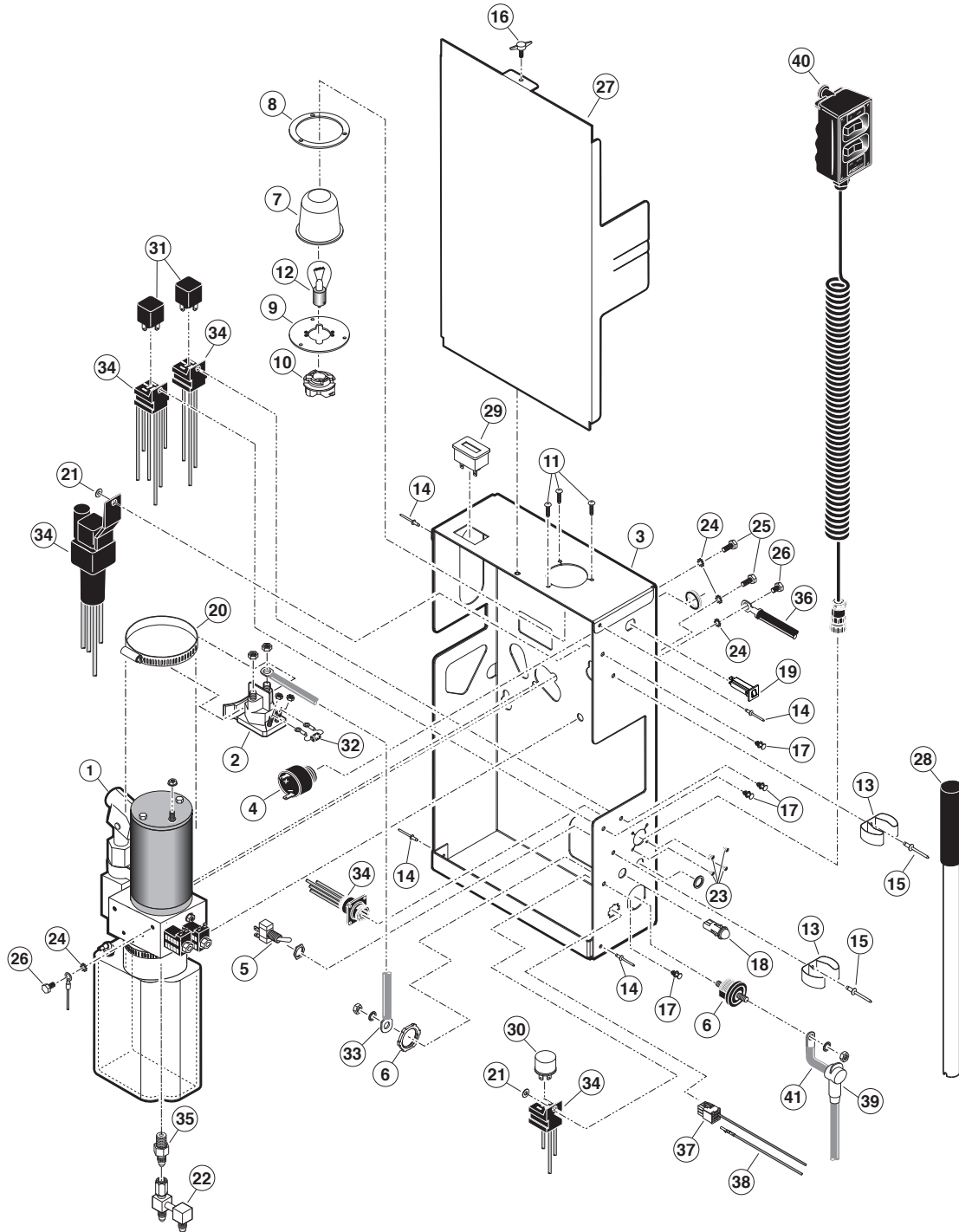

Note: Left (rear) pump module shown, right (front) pump module mirror image.



# Exploded Views and Parts Lists

## Base Plate Assembly

### Applicable Lifts:

**NCL9171B-2**  
**NCL9171B3354-2**

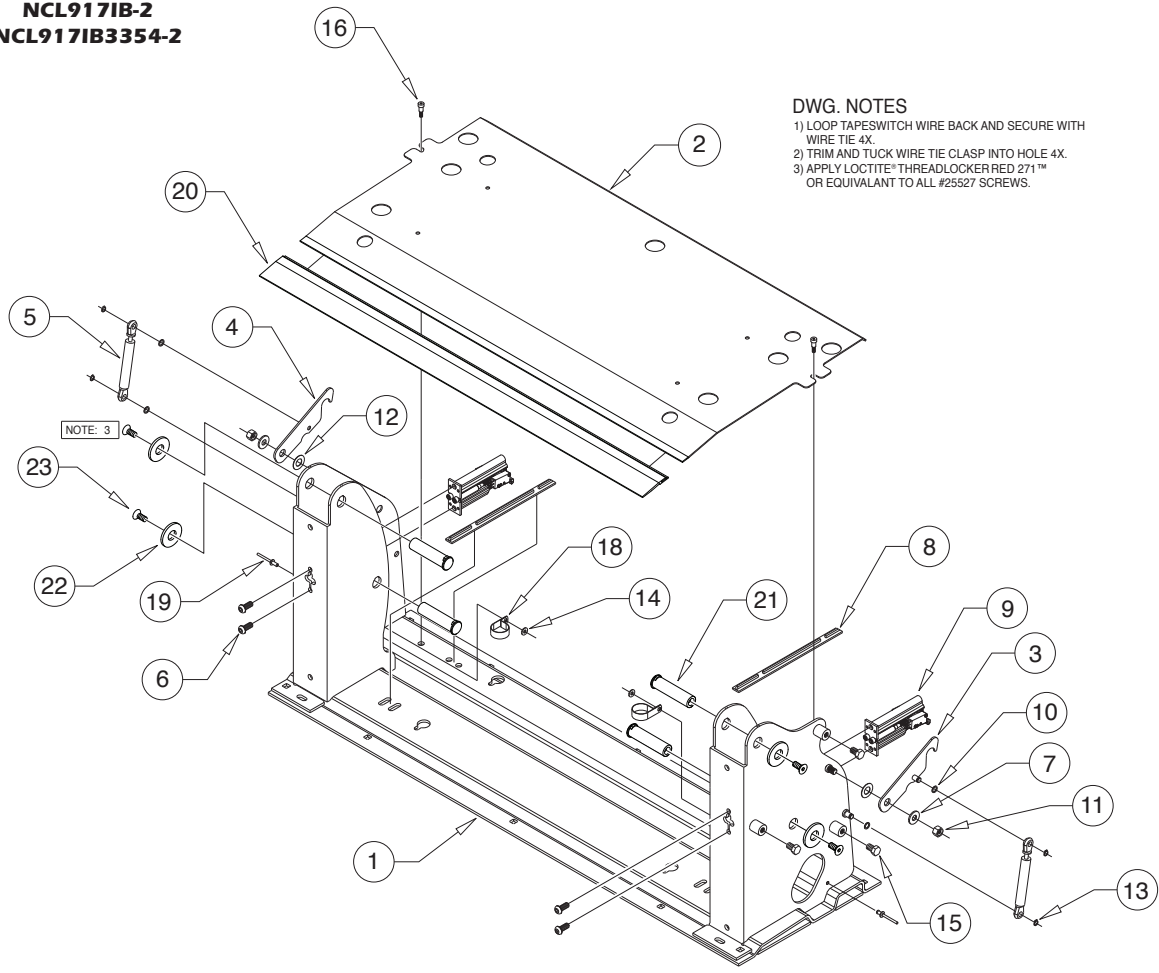

**DWG. NOTES**  
 1) LOOP TAPESWITCH WIRE BACK AND SECURE WITH WIRE TIE 4X.  
 2) TRIM AND TUCK WIRE TIE CLASP INTO HOLE 4X.  
 3) APPLY LOCTITE® THREADLOCKER RED 271™ OR EQUIVALENT TO ALL #25527 SCREWS.

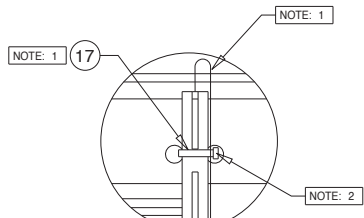
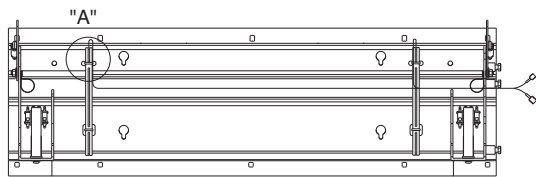

**DETAIL A**  
 (SCALE = 4X)

ITEM	QTY.	PART NO.	DESCRIPTION
23	4	25527	SCREW-5/16-18 X 3/4" FHS/AUTO-BK
22	4	25346	WASHER-1/2" FLAT-BK
21	4	936-0403	PIN-PIVOT PARALLEL ARM
20	1	36075KS	KIT-THRESHOLD TRANSITION-RUBBER NOSE
19	2	14993	RIV-POP-SD66BS-3/16"- .25/38/AUTO-BK
18	2	29765	CLAMP-INSULATED-1 3/8"
17	4	10091	CABLE TIE-11" SOLID
16	2	31816	BOLT-SHOULDER, 5/16 X 5/8-1/4-20 SS W/PC
15	3	29729	BOLT-3/8-16 X 1/2 W/NYLOCK PATCH
14	2	11541	WASHER-#10 FLAT/AUTO-BK
13	4	24570	RING-5/16 EXT SNAP/ZINC PLATED
12	2	11913	WASHER-1/2" NYLON
11	2	28339BK	NUT-3/8-16 TOP LOCK/AUTO-BK
10	4	26614	O-RING 5/16 ID X 1/16
9	2	975-4121A	MICRO SWITCH ASSY
8	2	33337A	ASSY-THRESHOLD-STRIP SWITCH-NHTSA/945
7	2	10063	WASHER-5/16 FLAT
6	4	24440	BOLT-5/16-18 X 3/4-BHSC/AUTO-BK
5	2	26963	SPRING-DAMP5.67 E/4.291 C,P1=3.37N-RET
4	1	27208RWBMB	WMT-LATCH-LIFT-TITE REAR-RETRO
3	1	27208FWBMB	WMT-LATCH-LIFT-TITE FRONT-RETRO
2	1	945-2148KS-33Y	KIT-BASE COVER - 33"
1	1	945-3148RNW33BM	WMT-BASE-REAR/48" FTG



# Exploded Views and Parts Lists

## Base Plate Assembly

**Applicable Lifts:**

**NCL917FIB-2  
NCL917FIB3354-2**

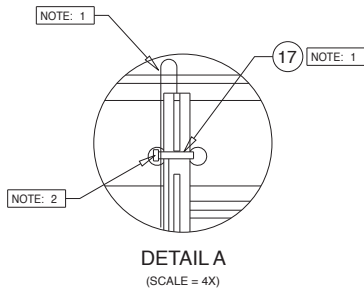
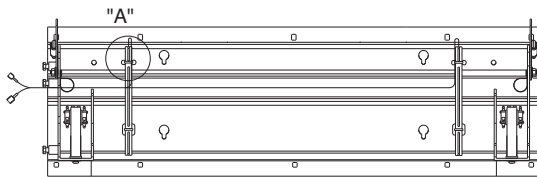
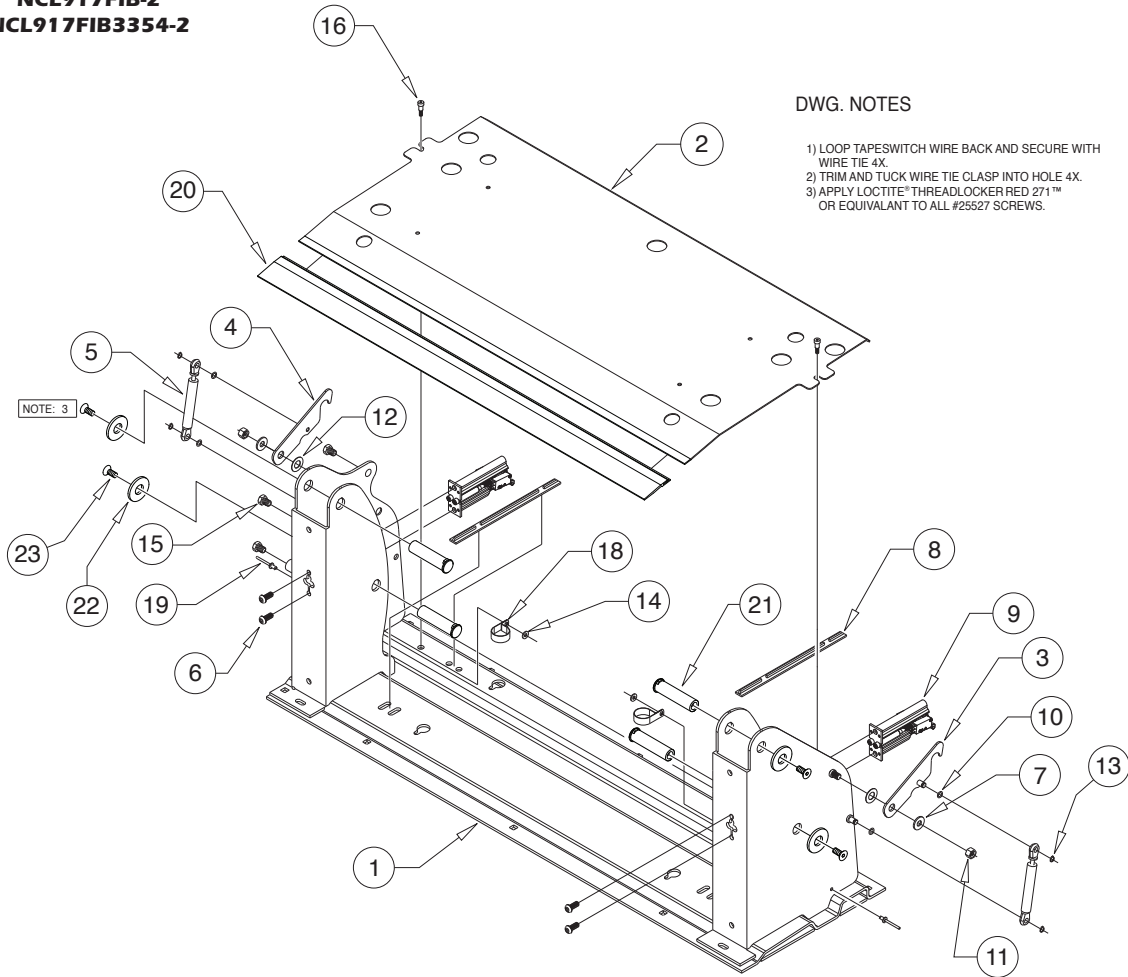

ITEM	QTY.	PART NO.	DESCRIPTION
23	4	25527	SCREW-5/16-18 X 3/4" FHS/AUTO-BK
22	4	25346	WASHER-1/2" FLAT-BK
21	4	936-0403	PIN-PIVOT PARALLEL ARM
20	1	36075KS	KIT-THRESHOLD TRANSITION-RUBBER NOSE
19	2	14993	RIV-POP-SD66BS-3/16"-.25/.38/AUTO-BK
18	2	29765	CLAMP-INSULATED-1 3/8"
17	4	10091	CABLE TIE-11" SOLID
16	2	31816	BOLT-SHOULDER, 5/16 X 5/8-1/4-20 SS W/PC
15	3	29729	BOLT-3/8-16 X 1/2 W/NYLOCK PATCH
14	2	11541	WASHER-#10 FLAT/AUTO-BK
13	4	24570	RING-5/16 EXT SNAP/ZINC PLATED
12	2	11913	WASHER-1/2" NYLON
11	2	28339BK	NUT-3/8-16 TOP LOCK/AUTO-BK
10	4	26614	O-RING 5/16 ID X 1/16
9	2	975-4121A	MICRO SWITCH ASSY
8	2	33337A	ASSY-THRESHOLD-STRIP SWITCH-NHTSA/945
7	2	10063	WASHER-5/16 FLAT
6	4	24440	BOLT-5/16-18 X 3/4-BHSC/AUTO-BK
5	2	26963	SPRING-DAMP5.67 E/4.291 C,P1=3.37N-RET
4	1	27208RWBM	WMT-LATCH-LIFT-TITE REAR-RETRO
3	1	27208FWBM	WMT-LATCH-LIFT-TITE FRONT-RETRO
2	1	945-2148KS-33Y	KIT-BASE COVER - 33"
1	1	945-3148FNW33BM	WMT-BASE-REAR/48" FTG

# Exploded Views and Parts Lists

## Base Plate Assembly

### Applicable Lifts:

NCL9191B-2  
NCL9171B3454-2

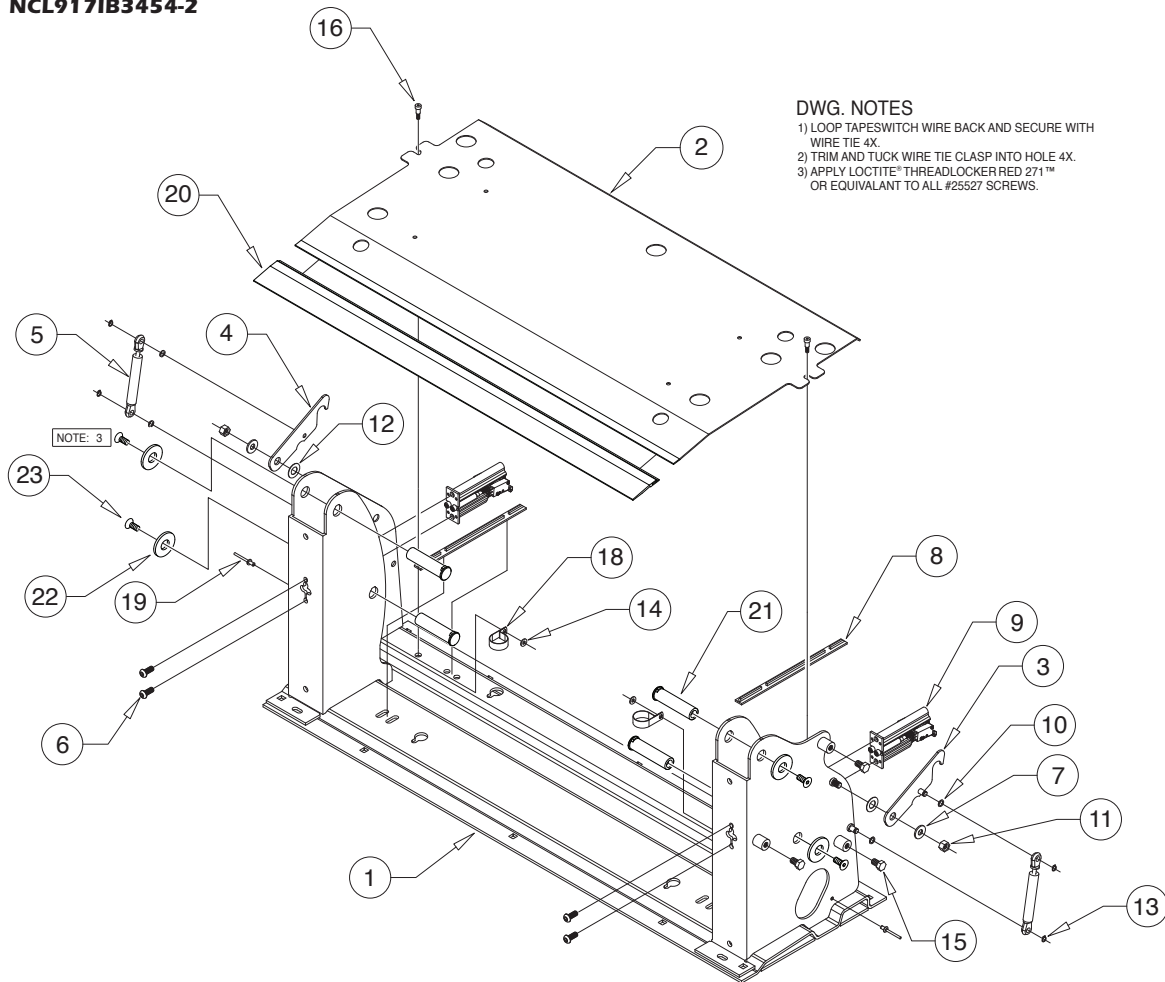

### DWG. NOTES

- 1) LOOP TAPESWITCH WIRE BACK AND SECURE WITH WIRE TIE 4X.
- 2) TRIM AND TUCK WIRE TIE CLASP INTO HOLE 4X.
- 3) APPLY LOCTITE™ THREADLOCKER RED 271™ OR EQUIVALANT TO ALL #25527 SCREWS.

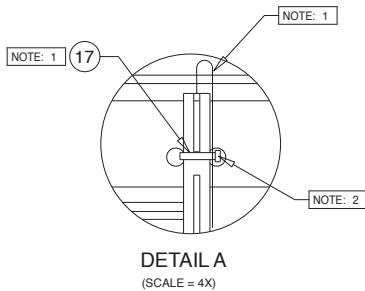
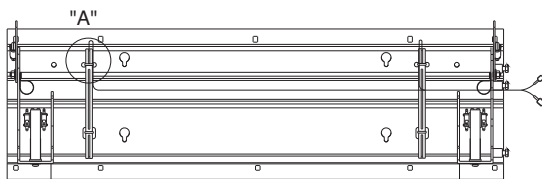

ITEM	QTY.	PART NO.	DESCRIPTION
23	4	25527	SCREW-5/16-18 X 3/4" FHS/AUTO-BK
22	4	25346	WASHER-1/2" FLAT-BK
21	4	936-0403	PIN-PIVOT PARALLEL ARM
20	1	36075KS	KIT-THRESHOLD TRANSITION-RUBBER NOSE
19	2	14993	RIV-POP-SD66BS-3/16"-.25/38/AUTO-BK
18	2	29765	CLAMP-INSULATED-1 3/8"
17	4	10091	CABLE TIE-11" SOLID
16	2	31816	BOLT-SHOULDER, 5/16 X 5/8-1/4-20 SS W/PC
15	3	29729	BOLT-3/8-16 X 1/2 W/NYLOCK PATCH
14	2	11541	WASHER-#10 FLAT/AUTO-BK
13	4	24570	RING-5/16 EXT SNAP/ZINC PLATED
12	2	11913	WASHER-1/2" NYLON
11	2	28339BK	NUT-3/8-16 TOP LOCK/AUTO-BK
10	4	26614	O-RING 5/16 ID X 1/16
9	2	975-4121A	MICRO SWITCH ASSY
8	2	33337A	ASSY-THRESHOLD-STRIP SWITCH-NHTSA/945
7	2	10063	WASHER-5/16 FLAT
6	4	24440	BOLT-5/16-18 X 3/4-BHSC/AUTO-BK
5	2	26963	SPRING-DAMP5.67 E/4.291 C,P1=3.37N-RET
4	1	27208RWBM	WMT-LATCH-LIFT-TITE REAR-RETRO
3	1	27208FWBM	WMT-LATCH-LIFT-TITE FRONT-RETRO
2	1	945-2148KS-34Y	KIT-BASE COVER - 34"
1	1	945-3148RNW34BM	WMT-BASE-REAR/48" FTG

# Exploded Views and Parts Lists

## Base Plate Assembly

### Applicable Lifts:

**NCL919FIB-2**  
**NCL917FIB3454-2**

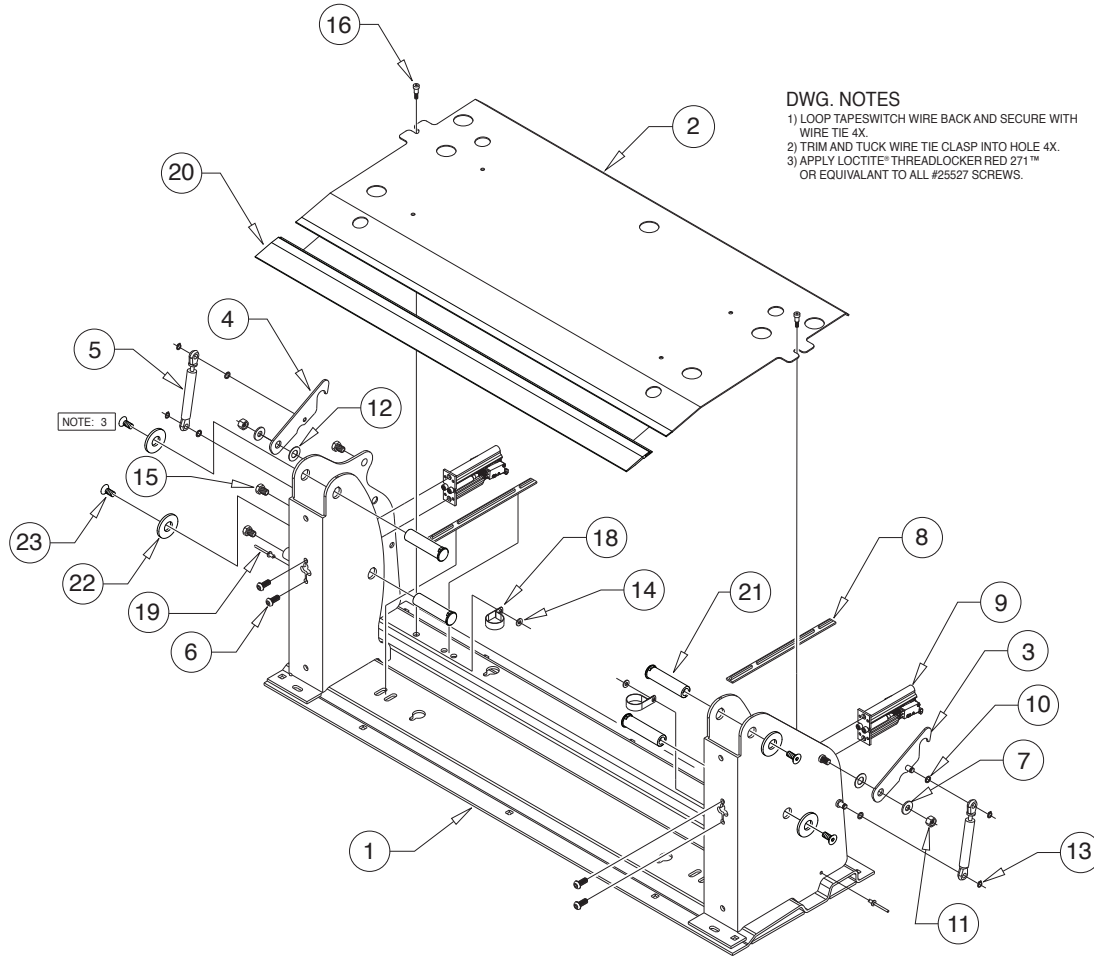

**DWG. NOTES**  
 1) LOOP TAPESWITCH WIRE BACK AND SECURE WITH WIRE TIE 4X.  
 2) TRIM AND TUCK WIRE TIE CLASP INTO HOLE 4X.  
 3) APPLY LOCTITE® THREADLOCKER RED 271™ OR EQUIVALANT TO ALL #25527 SCREWS.

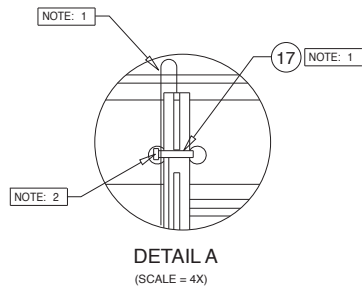
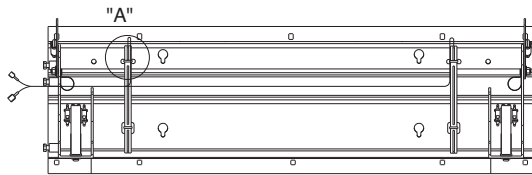

ITEM	QTY.	PART NO.	DESCRIPTION
23	4	25527	SCREW-5/16-18 X 3/4" FHS/AUTO-BK
22	4	25346	WASHER-1/2" FLAT-BK
21	4	936-0403	PIN-PIVOT PARALLEL ARM
20	1	36075KS	KIT-THRESHOLD TRANSITION-RUBBER NOSE
19	2	14993	RIV-POP-SD66BS-3/16"-25/38/AUTO-BK
18	2	29765	CLAMP-INSULATED-1 3/8"
17	4	10091	CABLE TIE-11" SOLID
16	2	31816	BOLT-SHOULDER, 5/16 X 5/8-1/4-20 SS W/PC
15	3	29729	BOLT-3/8-16 X 1/2 W/NYLOCK PATCH
14	2	11541	WASHER-#10 FLAT/AUTO-BK
13	4	24570	RING-5/16 EXT SNAP/ZINC PLATED
12	2	11913	WASHER-1/2" NYLON
11	2	28339BK	NUT-3/8-16 TOP LOCK/AUTO-BK
10	4	26614	O-RING 5/16 ID X 1/16
9	2	975-4121A	MICRO SWITCH ASSY
8	2	33337A	ASSY-THRESHOLD-STRIP SWITCH-NHTSA/945
7	2	10063	WASHER-5/16 FLAT
6	4	24440	BOLT-5/16-18 X 3/4-BHSC/AUTO-BK
5	2	26963	SPRING-DAMP.67 E/4.291 C,P1=3.37N-RET
4	1	27208RWBM	WMT-LATCH-LIFT-TITE REAR-RETRO
3	1	27208FWBM	WMT-LATCH-LIFT-TITE FRONT-RETRO
2	1	945-2148KS-34Y	KIT-BASE COVER - 34"
1	1	945-3148FNW34BM	WMT-BASE-REAR/48" FTG

# Exploded Views and Parts Lists

## Top Parallel Arm Assembly - Front

**Applicable Lifts:**

**All NCL917's**  
**All NCL919's**

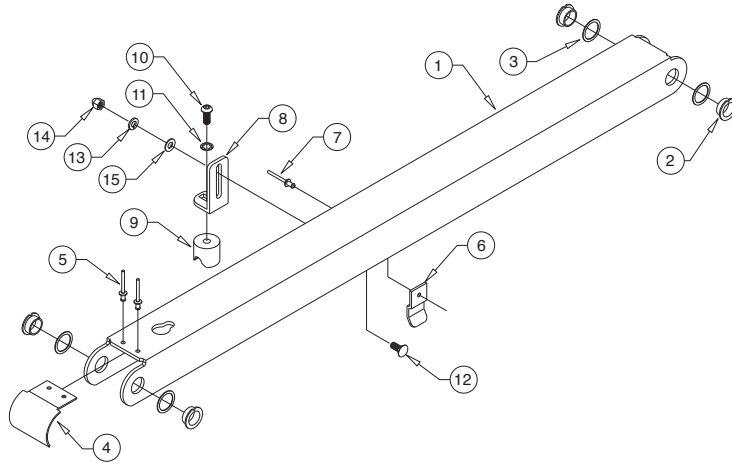

ITEM	QTY.	PART NO.	DESCRIPTION
15	1	10062	WASHER-1/4" FLAT/AUTO-BK
14	1	30996BK	NUT-5/16-18 ACORN
13	1	10068	WASHER-5/16" LOCK/AUTO-BK
12	1	15858BK	BOLT-CARR 5/16-18 X 3/4/AUTO-BK
11	1	16368	WASHER-5/16" EXTERNAL TOOTH
10	1	24440	BOLT-5/16-18 X 3/4-BHSC/AUTO-BK
9	1	28593A	ASSY-BLOCK-GUIDE-PLATFORM-STOW
8	1	955-2392CLXTBM	BKT.-QUIET-RIDE MTG.-955
7	1	14993	RIV-POP-SD66BS-3/16"- .25/.38/AUTO-BK
6	1	915-0703BM	BRACKET-INNER SIDE PANEL GUIDE
5	2	11513	RIV-POP-SD64BS-3/16"- .13/.25/AUTO-BK
4	1	945-0450BM	CAP-PARALLEL ARM
3	4	34398	WASHER-0.906"ID X 1.25"OD X .075"TH/ZINC
2	4	24011	BEARING-FLANGE-3/4" X 3/8"-12FDU06
1	1	945-3419FNA	ARM-PARALLEL/TOP-FRONT (Incl. Items 1-15)

## Top Parallel Arm Assembly - Rear

**Applicable Lifts:**

**All NCL917's**  
**All NCL919's**

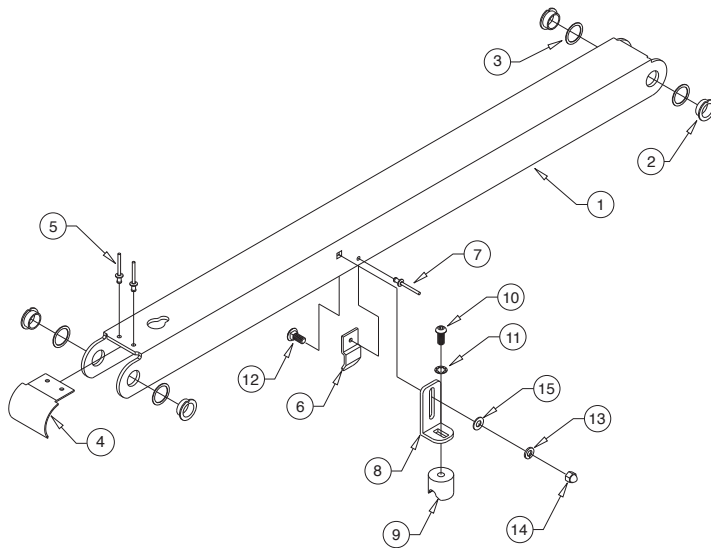

ITEM	QTY.	PART NO.	DESCRIPTION
15	1	10062	WASHER-1/4" FLAT/AUTO-BK
14	1	30996BK	NUT-5/16-18 ACORN
13	1	10068	WASHER-5/16" LOCK/AUTO-BK
12	1	15858BK	BOLT-CARR 5/16-18 X 3/4/AUTO-BK
11	1	16368	WASHER-5/16" EXTERNAL TOOTH
10	1	24440	BOLT-5/16-18 X 3/4-BHSC/AUTO-BK
9	1	28593A	ASSY-BLOCK-GUIDE-PLATFORM-STOW
8	1	955-2392CLXTBM	BKT.-QUIET-RIDE MTG.-955
7	1	14993	RIV-POP-SD66BS-3/16"- .25/.38/AUTO-BK
6	1	915-0703BM	BRACKET-INNER SIDE PANEL GUIDE
5	2	11513	RIV-POP-SD64BS-3/16"- .13/.25/AUTO-BK
4	1	945-0450BM	CAP-PARALLEL ARM
3	4	34398	WASHER-0.906"ID X 1.25"OD X .075"TH/ZINC
2	4	24011	BEARING-FLANGE-3/4" X 3/8"-12FDU06
1	1	945-3419RNA	ARM-PARALLEL/TOP/48" FTG/R (Incl. Items 1-15)

## Exploded Views and Parts Lists Bottom Parallel Arm Assembly - Rear

**Applicable Lifts:**

**All NCL917's  
All NCL919's**

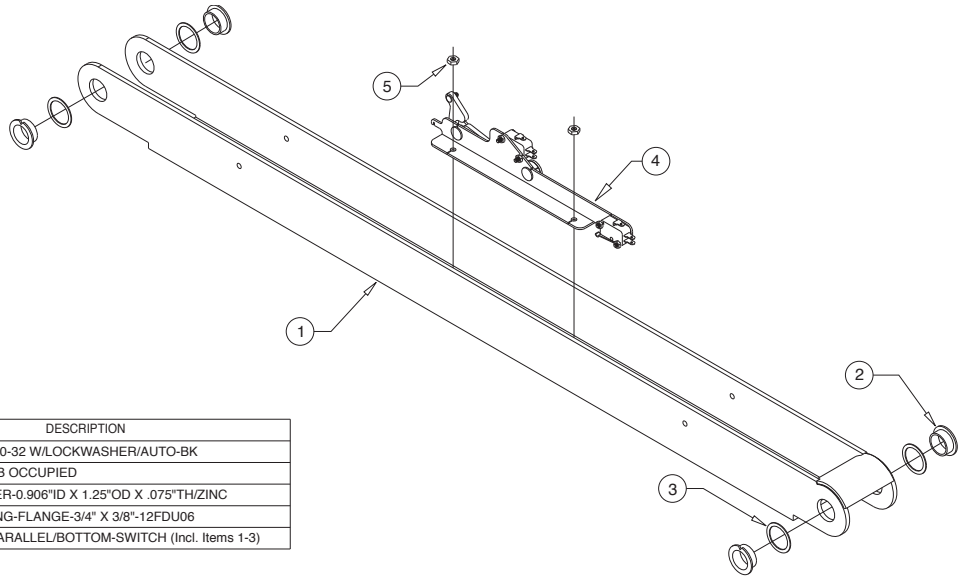

ITEM	QTY.	PART NO.	DESCRIPTION
5	2	18349	NUT-#10-32 W/LOCKWASHER/AUTO-BK
4	1	32514NA	ASSY-IB OCCUPIED
3	4	34398	WASHER-0.906"ID X 1.25"OD X .075"TH/ZINC
2	4	24011	BEARING-FLANGE-3/4" X 3/8"-12FDU06
1	1	945-345BNKS	ARM-PARALLEL/BOTTOM-SWITCH (Incl. Items 1-3)

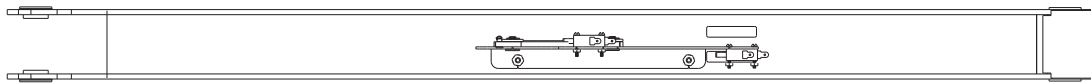

## Bottom Parallel Arm Assembly - Front

**Applicable Lifts:**

**All NCL917's  
All NCL919's**

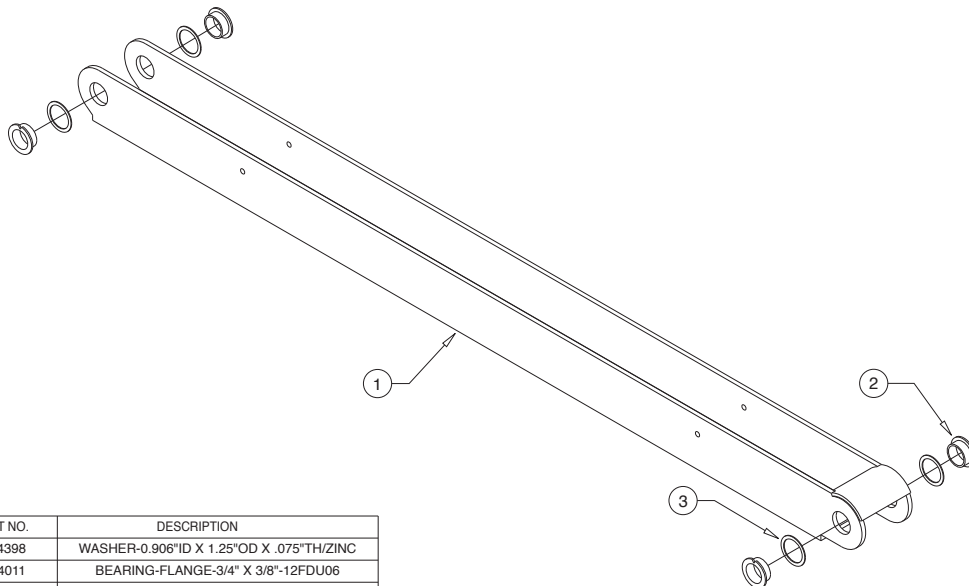

ITEM	QTY.	PART NO.	DESCRIPTION
3	4	34398	WASHER-0.906"ID X 1.25"OD X .075"TH/ZINC
2	4	24011	BEARING-FLANGE-3/4" X 3/8"-12FDU06
1	1	945-3412NA	ARM-PARALLEL/BOTTOM (Incl. Items 1-3)

# Exploded Views and Parts Lists

## Hydraulic Cylinder Assembly - Main

**Applicable Lifts:**

All NCL917's  
All NCL919's

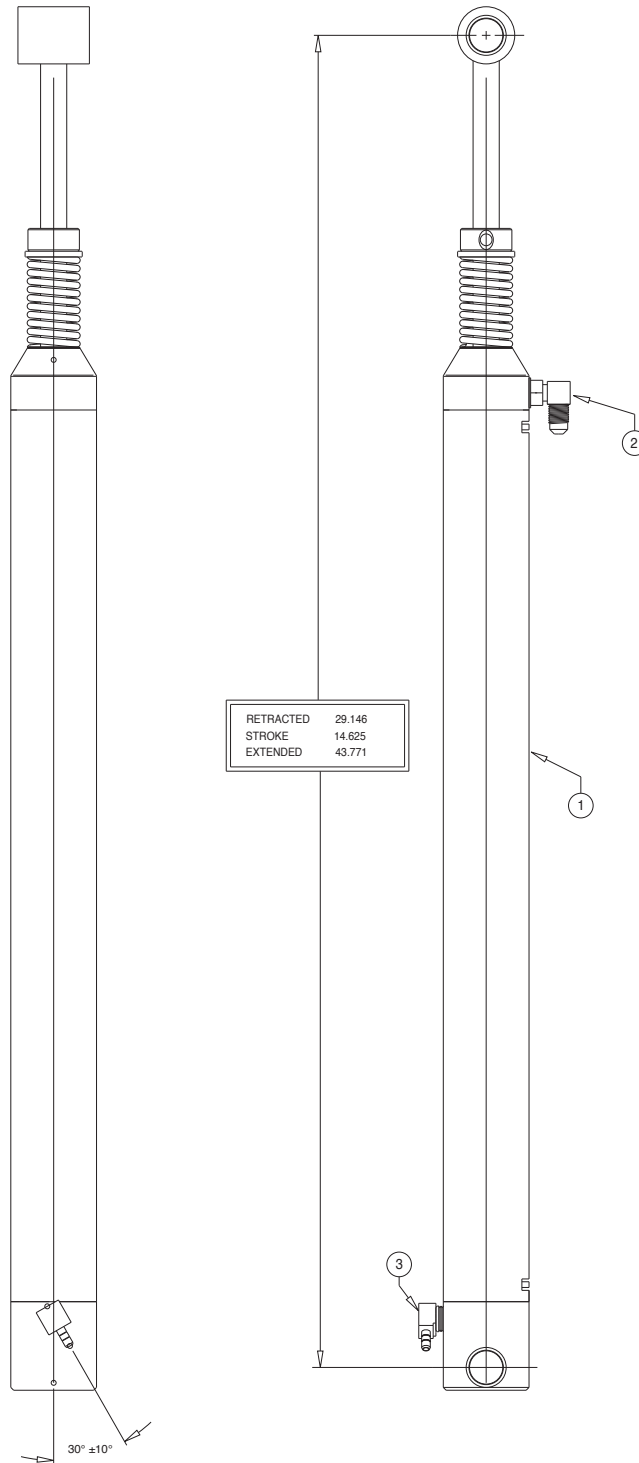

ITEM	QTY.	PART NO.	DESCRIPTION
3	1	15150	ELBOW-1/4 NPT 90° 1/4 BARB
2	1	26667	ELBOW-7/16-20 M/O-RNG/37/.035 ORFICE
1	1	C1514.3-0408NBM	CYLINDER-14.625'/29.146 RETRACTED

# Exploded Views and Parts Lists

## Vertical Arm Assembly - Front

### Applicable Lifts:

**All NCL917's**  
**All NCL919's**

### DWG. NOTES

- 1) INSERT SOCKET OF LIGHT ASSY THRU TOP KEY WHILE INSTALLING LIGHT. TIGHTEN SCREWS.
- 2) APPLY LOCTITE® THREADLOCKER BLUE 242® OR EQUIVALENT
- 3) APPLY LOCTITE® THREADLOCKER RED 271™ OR EQUIVALENT TO ALL #25527 SCREWS.

ITEM	QTY.	PART NO.	DESCRIPTION
11	1	15886BK	COTTER PIN-1/4" X 2"/AUTO-BK
10	3	25527	SCREW-5/16-18 X 3/4" FHS/AUTO-BK
9	3	25346	WASHER-1/2" FLAT/AUTO-BK
8	3	936-0403	PIN-PIVOT PARALLEL
7	1	32408	RUBBER BUMPER-VERT CHAN.
6	1	81064-000	SCREW-1/4-20 X 1" BHCS SS
5	1	945-5353	RETAINER-LIFT TITE ROLLER
4	1	1000-2395A	ROLLER-ASSY-ARM-TORQUE SHAFT
3	4	30063	RIVET-PUSH IN-8MM
2	1	37968	LIGHT ASSY-LED PLATFORM LIGHT
1	1	945-3448FNWBM	WMT-VERTICAL CHANNEL-FRONT-48"

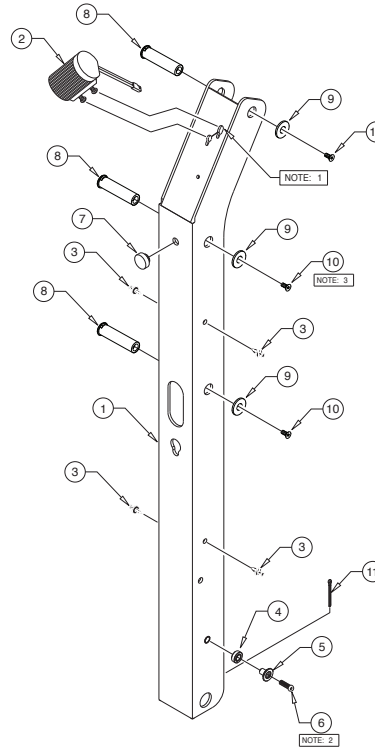

## Vertical Arm Assembly - Rear

### Applicable Lifts:

**All NCL917's**  
**All NCL919's**

### DWG. NOTES

- 1) INSERT SOCKET OF LIGHT ASSY THRU TOP KEY WHILE INSTALLING LIGHT. TIGHTEN SCREWS.
- 2) HARNESS TO BE TUCKED INSIDE CHANNEL.
- 3) APPLY LOCTITE® THREADLOCKER BLUE 242® OR EQUIVALENT
- 4) APPLY LOCTITE® THREADLOCKER RED 271™ OR EQUIVALENT TO ALL #25527 SCREWS.

ITEM	QTY.	PART NO.	DESCRIPTION
13	1	15886BK	COTTER PIN-1/4" X 2"/AUTO-BK
12	3	25346	WASHER-1/2" FLAT/AUTO BK
11	3	936-0403	PIN-PIVOT PARALLEL ARM
10	4	30063	RIVET-PUSH IN-8MM
9	2	37049	SCREW-#4-40 X 3/8" THREAD FORM
8	1	33689A	ASSY-BRIDGE SWITCH W/ HARN/NL/NCL-2
7	1	32408	RUBBER BUMPER-VERT CHAN.
6	1	81064-000	SCREW-1/4-20 X 1" BHCS SS
5	1	945-5353	RETAINER-LIFT TITE ROLLER
4	1	1000-2395A	ROLLER-ASSY-ARM-TORQUE SHAFT
3	3	25527	SCREW-5/16-18 X 3/4" FHS/AUTO-BK
2	1	37968	LIGHT ASSY-LED PLATFORM LIGHT
1	1	945-3448RNWBM	WMT-VERTICAL CHANNEL-REAR-48"

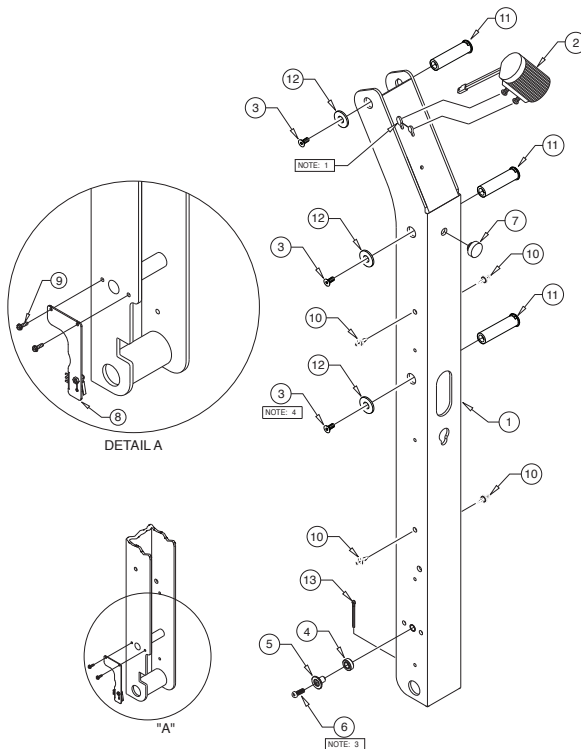

# Exploded Views and Parts Lists

## Arm Cover Assembly - Front

**Applicable Lifts:**

All NCL917's  
All NCL919's

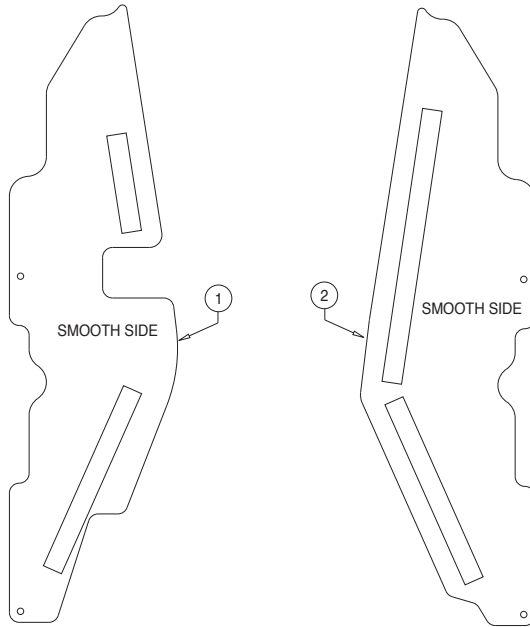

ITEM	QTY.	PART NO.	DESCRIPTION
2	1	915-0704NA	COVER-PLASTIC-PARALLEL ARM-OUTSIDE-FRONT
1	1	945-0701NA	COVER-PLASTIC-PARALLEL ARM-INSIDE-FRONT

## Arm Cover Assembly - Rear

**Applicable Lifts:**

All NCL917's  
All NCL919's

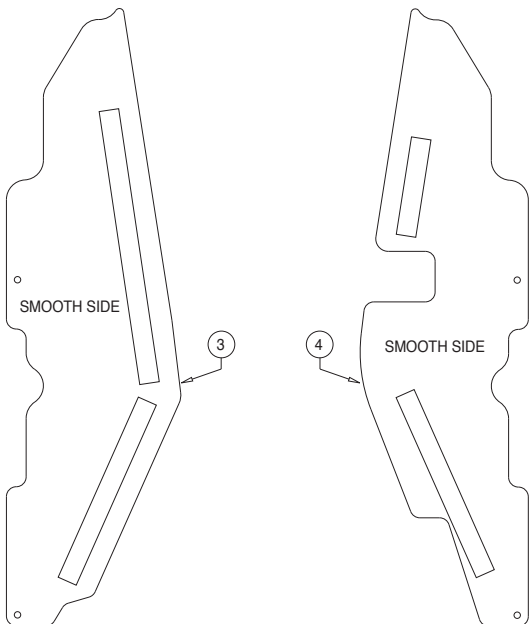

ITEM	QTY.	PART NO.	DESCRIPTION
4	1	945-0703NA	COVER-PLASTIC-PARALLEL ARM-INSIDE-REAR
3	1	915-0702NA	COVER-PLASTIC-PARALLEL ARM-OUTSIDE-REAR



# Exploded Views and Parts Lists

## Handrail Assembly - Front

### Applicable Lifts:

**All NCL917's**  
**All NCL919's**

ITEM	QTY.	PART NO.	DESCRIPTION
13	2	11513	RIV-POP-SD64BS-3/16"- .13/.25/AUTO-BK
12	1	10069	WASHER-3/8" LOCK
11	1	29186A	GAS SPRING-14.468 EXT/8.956 COM-P1=1150N
10	2	30227	SPACER-UHMW 0.75 OD X 0.39 ID X 0.25
9	1	13617	NUT-3/8-16 UNC HEX LOCK/AUTO-BK
8	1	945-0640FNA	ASSY-FOLD ARM-48 FTG-FRONT
7	1	31677	SLIDE-UHMW-PLATFORM SLIDE-2X6.9"
6	1	985-0606NBM	SLIDE-PLATFORM ROTATE HANDRAIL
5	1	900-0413N	PIN-PIVOT LOWER ARM
4	2	18657	RING-3/4 EXT SNAP/AUTO-BK
3	1	10027	BOLT-3/8-16 X 2" HEX HD. CAP
2	1	25171	BOLT-3/8-16 X 3/4" FLBHSCS-GD8
1	1	945-0618NA	HANDRAIL ASSY-NHTSA

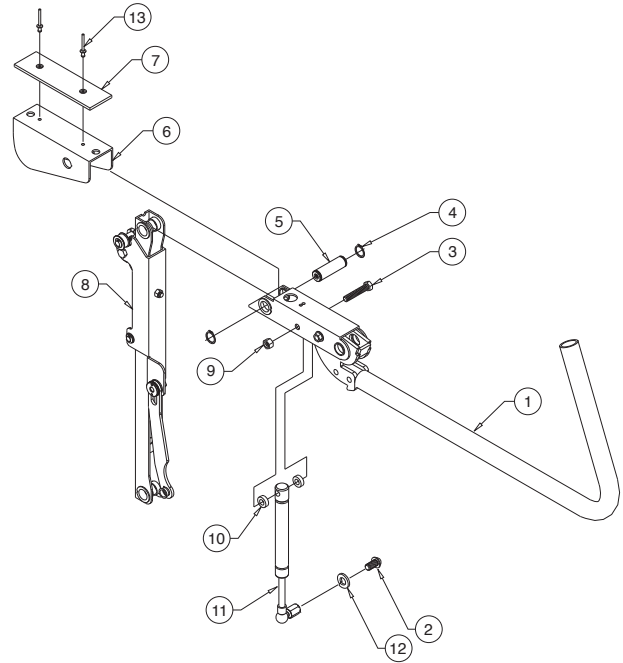

## Handrail Assembly - Rear

### Applicable Lifts:

**All NCL917's**  
**All NCL919's**

ITEM	QTY.	PART NO.	DESCRIPTION
14	1	* 32519A	SWITCH ASSEMBLY (INCLUDED WITH ITEM 9)
13	1	10069	WASHER-3/8" LOCK
12	1	29186A	GAS SPRING-14.468 EXT/8.956 COM-P1=1150N
11	2	30227	SPACER-UHMW 0.75 OD X 0.39 ID X 0.25
10	1	13617	NUT-3/8-16 UNC HEX LOCK/AUTO-BK
9	1	945-0640RNA	ASSY-FOLD ARM-48 FTG-REAR
8	2	11513	RIV-POP-SD64BS-3/16"- .13/.25/AUTO-BK
7	1	31677	SLIDE-UHMW-PLATFORM SLIDE-2X6.9"
6	1	985-0606NBM	SLIDE-PLATFORM ROTATE HANDRAIL
5	1	900-0413N	PIN-PIVOT LOWER ARM
4	2	18657	RING-3/4 EXT SNAP/AUTO-BK
3	1	10027	BOLT-3/8-16 X 2" HEX HD. CAP
2	1	25171	BOLT-3/8-16 X 3/4" FLBHSCS-GD8
1	1	945-0618NA	HANDRAIL ASSY-NHTSA

\* INDICATES ITEMS NOT SHOWN

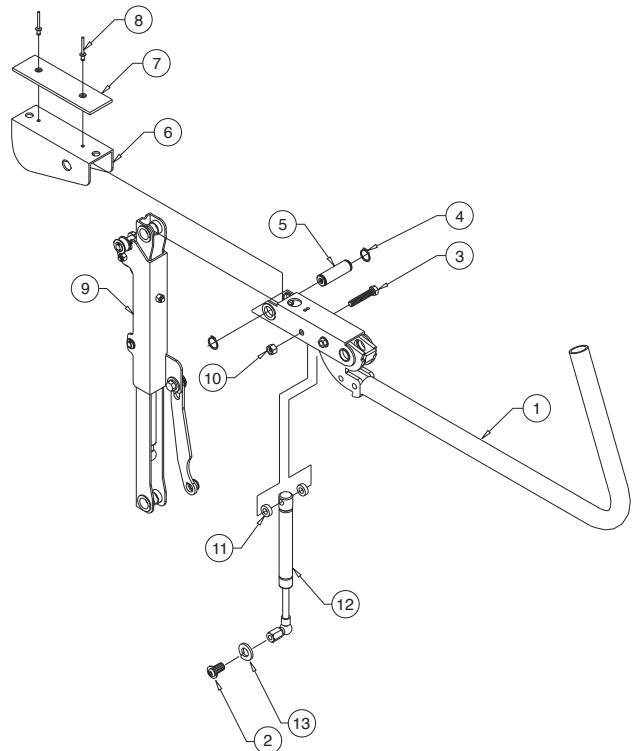

# Exploded Views and Parts Lists

## Platform Assembly

### Applicable Lifts:

**NCL917IB-2**  
**NCL917FIB-2**

### DWG. NOTES

- 1) USE LOCTITE® THREADLOCKER RED 271™ OR EQUIVALENT ON SCREWS (B.C. #24537 & B.C. #15733).
- 2) USE LOCTITE® THREADLOCKER GREEN 290™ OR EQUIVALENT ON CLEVIS PINS (B.C. #24932BK).
- 3) APPLY BOUNDARY DECAL (ITEM 33) 48 1/8" FROM FRONT EDGE OF PLATFORM TO LEADING EDGE OF DECAL.
- 4) INBOARD EDGE OF DECAL (ITEM 32) TO BEGIN AT 48 1/2".

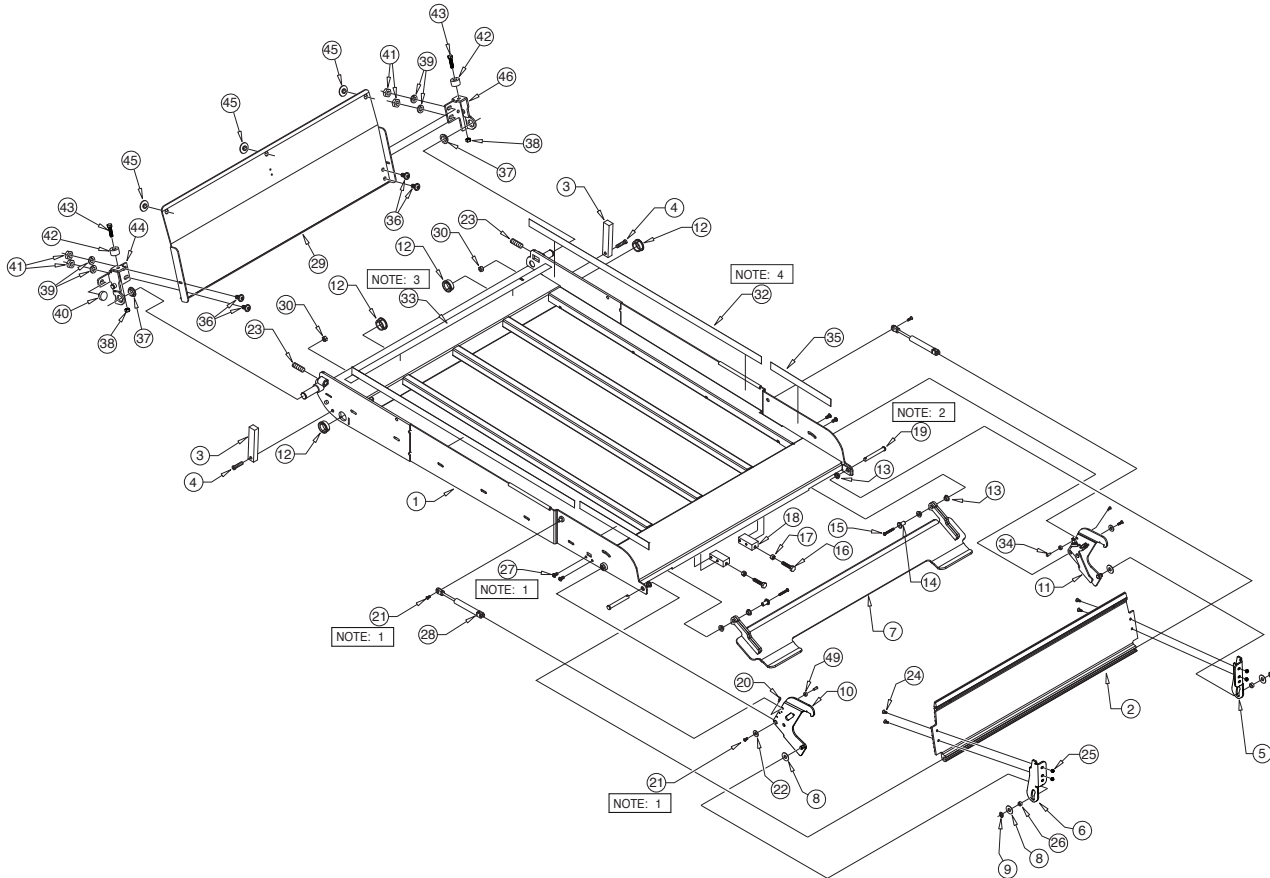

ITEM	QTY.	PART NO.	DESCRIPTION
26	2	945-2336N	BEARING-PLATFORM SLIDE
25	4	10775	NUT-1/4-20 HEX LOCK/AUTO-BK
24	4	40-4230-0	SCREW-1/4-20 X 5/8" FHSC
23	2	18663	SCREW-1/2-20 X 1.5 SET-LOCK/AUTO-BK
22	2	990-0341	ADAPT-CYL/ROLL STOP LEVER-OUT
21	4	24537	SCREW-#10-32X3/8 FL HD-HX SKT/AUTO-BK
20	2	36003	HAIRPIN COTTER-STAINLESS-.042"
19	2	24932BK	PIN-CLEVIS 3/8 X 3" EFF LEN.-W/O HOLE/BK
18	2	33411BM	BRACKET ADJUST-SPLIT FOOT
17	2	10058	NUT-5/16-18 HEX/AUTO-BK
16	2	10013	BOLT-5/16-18 X 1" HEX HD. CAP
15	2	40-1092-0	SCREW-10-32 X 1.25" SHCS
14	2	32759	STANDOFF-FOOT MOUNT
13	6	24028	BEARING-PLASTIC-FLANGE-3/8IDX1/4"
12	4	28031	BEARING-FLANGE-1 X 1/2-16FDU08
11	1	400375ABM	ASSY-ROLL STOP LATCH/OCCUPIED SWITCH-FRONT
10	1	945-4206FRNA	ASSY-ROLL STOP LATCH/OCCUPIED SWITCH-REAR
9	2	13889	RING-3/8 RETAINING SNAP
8	4	29371	WASHER-THRUST-.875 OD/.50 ID/.0585T
7	1	945-0200NW-33BM	ROLL STOP ACTIVATION FOOT
6	1	945-3202RNBM	BKT-LATCH/ROLL STOP/REAR
5	1	945-3202FNBM	BKT-LATCH/ROLL STOP/FRONT
4	2	81003-000	SCREW-5/16-18 X 1-1/4 SHCS BK ZINC
3	2	900-0311BM	STOP-PLATFORM
2	1	945-3312NA33YL	ROLL STOP-ALUM/RUBBER END/ASSY/33"
1	1	400364WBM	PLATFORM-NCL917IB-2 33" X 51"

ITEM	QTY.	PART NO.	DESCRIPTION
49	2	400213	LATCH SPACER
48	3	26362*	RIVET-SNAP BLACK-.201" X .256"/.295"
47	3	84396*	CLAMP-1/4" ID NYLON LOOP BLK
46	1	945-0431FNWBM	WMT-BKT-BRIDGE PLATE/FR
45	3	916-5406	BEARING-UHMW FLAT-THIN-BLK
44	1	945-0431RNWBM	WMT-BKT-BRIDGE PLATE/RR
43	2	10001	BOLT-1/4-20 X 1" HEX
42	2	33603	BUMPER-1" X 5/8" LG NAT UHMW/BRIDGEPLATE
41	4	10059BK	NUT-3/8-16 HEX/AUTO-BK
40	1	32408	RUBBER BUMPER-VERT CHAN.
39	4	10069BK	WASHER-3/8" LOCK/AUTO-BK
38	2	14614Z	NUT-1/4-20 NYLOCK / AUTO - ZINC
37	2	24012	BEARING-FLANGE-3/4" X 1/4"-12FDU04
36	4	25171	BOLT-3/8-16 X 3/4" FLBHSCS-GD8
35	2	30236R011	DECAL-BOUNDARY YELLOW LEXAN 1" X 11"
34	2	401002	PIN-ROLLSTOP GAS SPRING
33	1	30236R032.5	DECAL-BOUNDARY YELLOW LEXAN 1" X 32 1/2"
32	2	30236R035.5	DECAL-BOUNDARY YELLOW LEXAN 1" X 35 1/2"
31	8	91010-000 *	CABLE TIE 3 3/4" BLACK
30	2	28324BK	NUT-5/16-18 TOP LOCK/AUTO-BK
29	1	915-0147NWYL	WMT-BRIDGE PLATE-PLT-33/48" FTG (945-0147NAVY INCL 29, 36-46)
28	2	32831	GAS-SPRING-30LB-3.54X9.65
27	4	15733	BOLT-1/4-20X1/2" BUT HD SOC/AUTO-BK

\* ITEMS NOT SHOWN

# Exploded Views and Parts Lists

## Platform Assembly

**Applicable Lifts:**

**NCL9171B3354-2**  
**NCL9171B3354-2**

**DWG. NOTES**

- 1) USE LOCTITE® THREADLOCKER RED 271™ OR EQUIVALENT ON SCREWS (B.C. #24537 & B.C. #15733).
- 2) USE LOCTITE® THREADLOCKER GREEN 290™ OR EQUIVALENT ON CLEVIS PINS (B.C. #24932BK)
- 3) APPLY BOUNDARY DECAL (ITEM 33) 48 1/8" FROM FRONT EDGE OF PLATFORM TO LEADING EDGE OF DECAL.
- 4) INBOARD EDGE OF DECAL (ITEM 32) TO BEGIN AT 48 1/2"

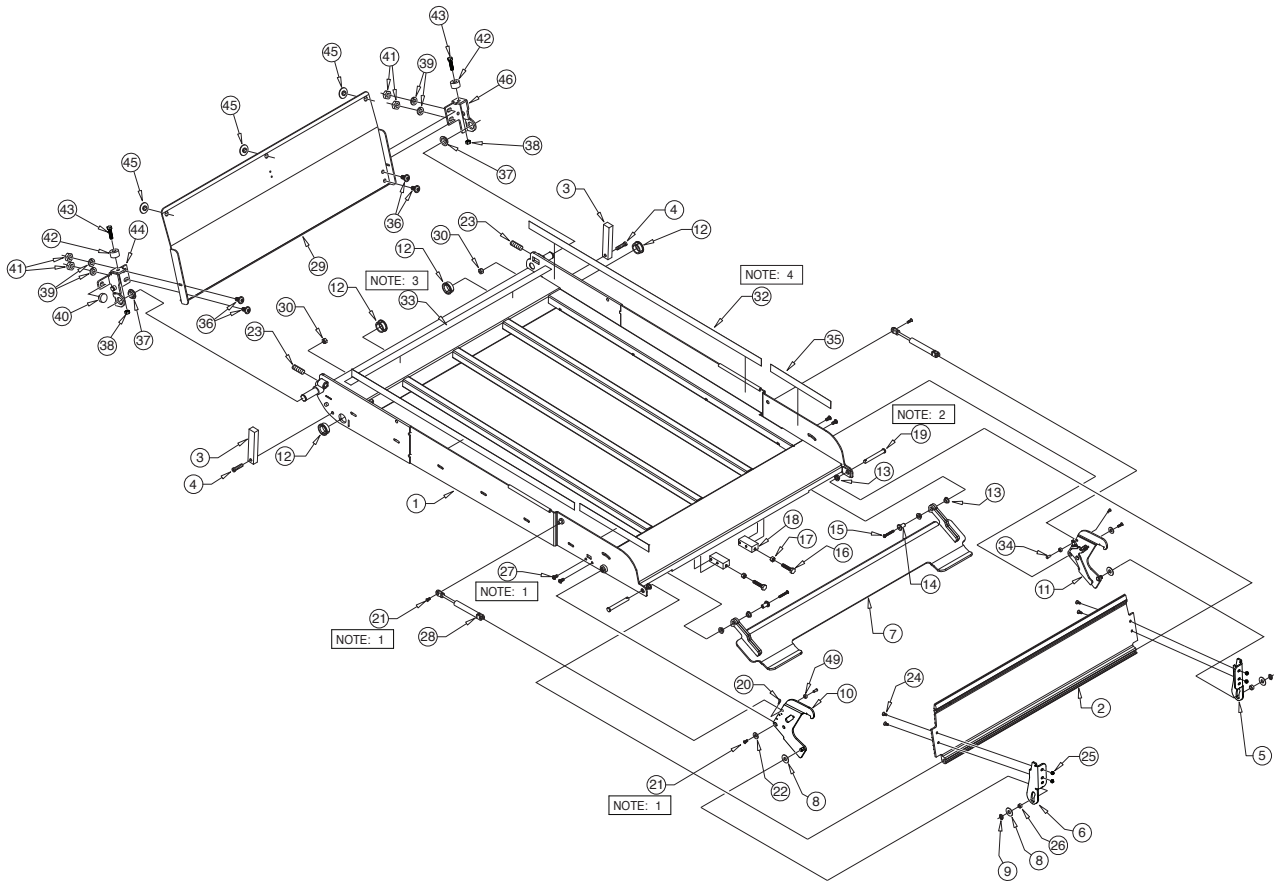

ITEM	QTY.	PART NO.	DESCRIPTION
26	2	945-2336N	BEARING-PLATFORM SLIDE
25	4	10775	NUT-1/4-20 HEX LOCK/AUTO-BK
24	4	40-4230-0	SCREW-1/4-20 X 5/8" FHSC
23	2	18663	SCREW-1/2-20 X 1.5 SET-LOCK/AUTO-BK
22	2	990-0341	ADAPT-CYL/ROLL STOP LEVER-OUT
21	4	24537	SCREW-#10-32X3/8 FL HD-HX SKT/AUTO-BK
20	2	36003	HAIRPIN COTTER-STAINLESS-.042"
19	2	24932BK	PIN-CLEVIS 3/8 X 3" EFF LEN.-W/O HOLE/BK
18	2	33411BM	BRACKET ADJUST-SPLIT FOOT
17	2	10058	NUT-5/16-18 HEX/AUTO-BK
16	2	10013	BOLT-5/16-18 X 1" HEX HD. CAP
15	2	40-1092-0	SCREW-10-32 X 1.25" SHCS
14	2	32759	STANDOFF-FOOT MOUNT
13	6	24028	BEARING-PLASTIC-FLANGE-3/8IDX1/4"
12	4	28031	BEARING-FLANGE-1 X 1/2-16FDU08
11	1	400375ABM	ASSY-ROLL STOP LATCH/OCCUPIED SWITCH-FRONT
10	1	945-4206RNA	ASSY-ROLL STOP LATCH/OCCUPIED SWITCH-REAR
9	2	13889	RING-3/8 RETAINING SNAP
8	4	29371	WASHER-THRUST-.875 OD/.50 ID/.0585T
7	1	945-0200NW-33BM	ROLL STOP ACTIVATION FOOT
6	1	945-3202RNBM	BKT-LATCH/ROLL STOP/REAR
5	1	945-3202FNBM	BKT-LATCH/ROLL STOP/FRONT
4	2	81003-000	SCREW-5/16-18 X 1-1/4 SHCS BK ZINC
3	2	900-0311BM	STOP-PLATFORM
2	1	945-3312NA33YL	ROLL STOP-ALUM/RUBBER END/ASSY/33"
1	1	400366WBM	PLATFORM-NCL9171B-2 33" X 54"

ITEM	QTY.	PART NO.	DESCRIPTION
49	2	400213	LATCH SPACER
48	3	26362*	RIVET-SNAP BLACK-.201" X .256"/.295"
47	3	84396*	CLAMP-1/4" ID NYLON LOOP BLK
46	1	945-0431FNWBM	WMT-BKT-BRIDGE PLATE/FR
45	3	916-5406	BEARING-UHMW FLAT-THIN-BLK
44	1	945-0431RNWBM	WMT-BKT-BRIDGE PLATE/RR
43	2	10001	BOLT-1/4-20 X 1" HEX
42	2	33603	BUMPER-1" X 5/8" LG NAT UHMW/BRIDGEPLATE
41	4	10059BK	NUT-3/8-16 HEX/AUTO-BK
40	1	32408	RUBBER BUMPER-VERT CHAN.
39	4	10069BK	WASHER-3/8" LOCK/AUTO-BK
38	2	14614Z	NUT-1/4-20 NYLOCK / AUTO - ZINC
37	2	24012	BEARING-FLANGE-3/4" X 1/4"-12FDU04
36	4	25171	BOLT-3/8-16 X 3/4" FLBHSCS-GD8
35	2	30236R011	DECAL-BOUNDARY YELLOW LEXAN 1" X 11"
34	2	401002	PIN-ROLLSTOP GAS SPRING
33	1	30236R032.5	DECAL-BOUNDARY YELLOW LEXAN 1" X 32 1/2"
32	2	30236R039.5	DECAL-BOUNDARY YELLOW LEXAN 1" X 39 1/2"
31	8	91010-000 *	CABLE TIE 3 3/4" BLACK
30	2	28324BK	NUT-5/16-18 TOP LOCK/AUTO-BK
29	1	915-0147NWYL	WMT-BRIDGE PLATE-PLT-33/48" FTG (945-0147NAYL INCL 29, 36-46)
28	2	32831	GAS-SPRING-30LB-3.54X9.65
27	4	15733	BOLT-1/4-20X1/2" BUT HD SOC/AUTO-BK

\* ITEMS NOT SHOWN

# Exploded Views and Parts Lists

## Platform Assembly

### Applicable Lifts:

**NCL917IB3454-2**  
**NCL917FIB3454-2**

### DWG. NOTES

- 1) USE LOCTITE® THREADLOCKER RED 271™ OR EQUIVALENT ON SCREWS (B.C. #24537 & B.C. #15733).
- 2) USE LOCTITE® THREADLOCKER GREEN 290™ OR EQUIVALENT ON CLEVIS PINS (B.C. #24932BK).
- 3) APPLY BOUNDARY DECAL (ITEM 33) 48 1/8" FROM FRONT EDGE OF PLATFORM TO LEADING EDGE OF DECAL.
- 4) INBOARD EDGE OF DECAL (ITEM 32) TO BEGIN AT 48 1/2".

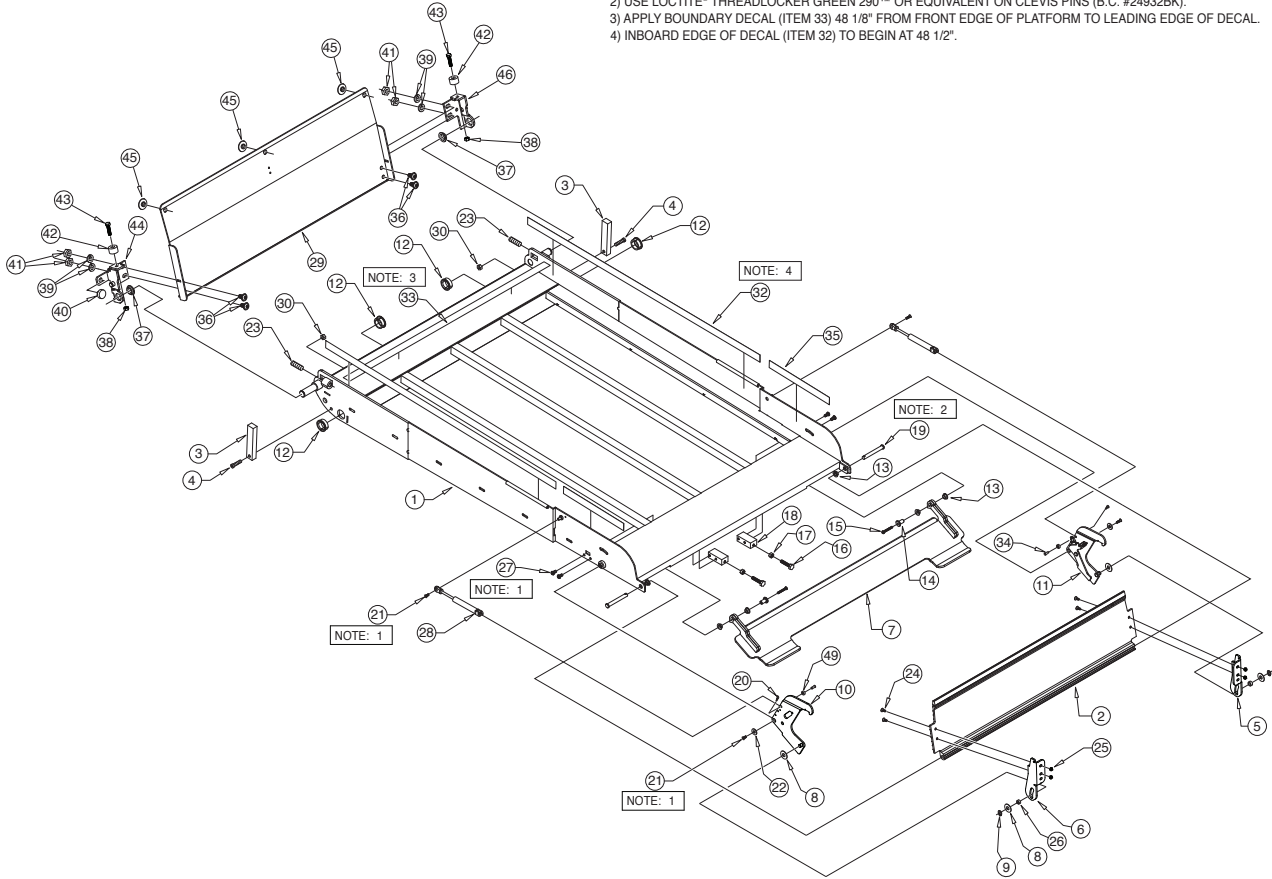

ITEM	QTY.	PART NO.	DESCRIPTION
26	2	945-2336N	BEARING-PLATFORM SLIDE
25	4	10775	NUT-1/4-20 HEX LOCK/AUTO-BK
24	4	40-4230-0	SCREW-1/4-20 X 5/8" FHSC
23	2	18663	SCREW-1/2-20 X 1.5 SET-LOCK/AUTO-BK
22	2	990-0341	ADAPT-CYL/ROLL STOP LEVER-OUT
21	4	24537	SCREW-#10-32X3/8 FL HD-HX SKT/AUTO-BK
20	2	36003	HAIRPIN COTTER-STAINLESS-.042"
19	2	24932BK	PIN-CLEVIS 3/8 X 3" EFF LEN.-W/O HOLE/BK
18	2	33411BM	BRACKET ADJUST-SPLIT FOOT
17	2	10058	NUT-5/16-18 HEX/AUTO-BK
16	2	10013	BOLT-5/16-18 X 1" HEX HD. CAP
15	2	40-1092-0	SCREW-10-32 X 1.25" SHCS
14	2	32759	STANDOFF-FOOT MOUNT
13	6	24028	BEARING-PLASTIC-FLANGE-3/8IDX1/4"
12	4	28031	BEARING-FLANGE-1 X 1/2-16FDU08
11	1	400375ABM	ASSY-ROLL STOP LATCH/OCCUPIED SWITCH-FRONT
10	1	945-4206RNA	ASSY-ROLL STOP LATCH/OCCUPIED SWITCH-REAR
9	2	13889	RING-3/8 RETAINING SNAP
8	4	29371	WASHER-THRUST-.875 OD/.50 ID/.0585T
7	1	945-0200NW-34BM	ROLL STOP ACTIVATION FOOT
6	1	945-3202RNBM	BKT-LATCH/ROLL STOP/REAR
5	1	945-3202FNBM	BKT-LATCH/ROLL STOP/FRONT
4	2	81003-000	SCREW-5/16-18 X 1 1/4 SHCS BK ZINC
3	2	900-0311BM	STOP-PLATFORM
2	1	945-3312NA34YL	ROLL STOP-ALUM/RUBBER END/ASSY/34"
1	1	400367WBM	PLATFORM-NCL919IB-2 34" X 54"

ITEM	QTY.	PART NO.	DESCRIPTION
49	2	400213	LATCH SPACER
48	3	26362*	RIVET-SNAP BLACK-.201" X .256"/.295"
47	3	84396*	CLAMP-1/4" ID NYLON LOOP BLK
46	1	945-0431FNWBM	WMT-BKT-BRIDGE PLATE/FR
45	3	916-5406	BEARING-UHMW FLAT-THIN-BLK
44	1	945-0431RNWBM	WMT-BKT-BRIDGE PLATE/RR
43	2	10001	BOLT-1/4-20 X 1" HEX
42	2	33603	BUMPER-1" X 5/8" LG NAT UHMW/BRIDGEPLATE
41	4	10059BK	NUT-3/8-16 HEX/AUTO-BK
40	1	32408	RUBBER BUMPER-VERT CHAN.
39	4	10069BK	WASHER-3/8" LOCK/AUTO-BK
38	2	14614Z	NUT-1/4-20 NYLOCK/AUTO - ZINC
37	2	24012	BEARING-FLANGE-3/4" X 1/4"-12FDU04
36	4	25171	BOLT-3/8-16 X 3/4" FLBHSCS-GD8
35	2	30236R011	DECAL-BOUNDARY YELLOW LEXAN 1" X 11"
34	2	401002	PIN-ROLLSTOP GAS SPRING
33	1	30236R032.5	DECAL-BOUNDARY YELLOW LEXAN 1" X 32 1/2"
32	2	30236R039.5	DECAL-BOUNDARY YELLOW LEXAN 1" X 39 1/2"
31	8	91010-000 *	CABLE TIE 3 3/4" BLACK
30	2	28324BK	NUT-5/16-18 TOP LOCK/AUTO-BK
29	1	915-0147NW34YL	WMT-BRIDGE PLATE-PLT-34/48" FTG (945-0147NA34YL INCL. 29, 36-48)
28	2	32831	GAS-SPRING-30LB-3.54X9.65
27	4	15733	BOLT-1/4-20 X 1/2" BUT HD SOC/AUTO-BK

\* ITEMS NOT SHOWN

# Exploded Views and Parts Lists

## Platform Assembly

### Applicable Lifts:

**NCL919IB-2**  
**NCL919FIB-2**

### DWG. NOTES

- 1) USE LOCTITE® THREADLOCKER RED 271™ OR EQUIVALENT ON SCREWS (B.C. #24537 AND B.C. 15733).
- 2) USE LOCTITE® THREADLOCKER GREEN 290™ OR EQUIVALENT ON CLEVIS PINS (B.C. #24932BK).
- 3) APPLY BOUNDARY DECAL (ITEM 33) 48 1/8" FROM FRONT EDGE OF PLATFORM TO LEADING EDGE OF DECAL.
- 4) INBOARD EDGE OF DECAL (ITEM 32) TO BEGIN AT 48 1/2".

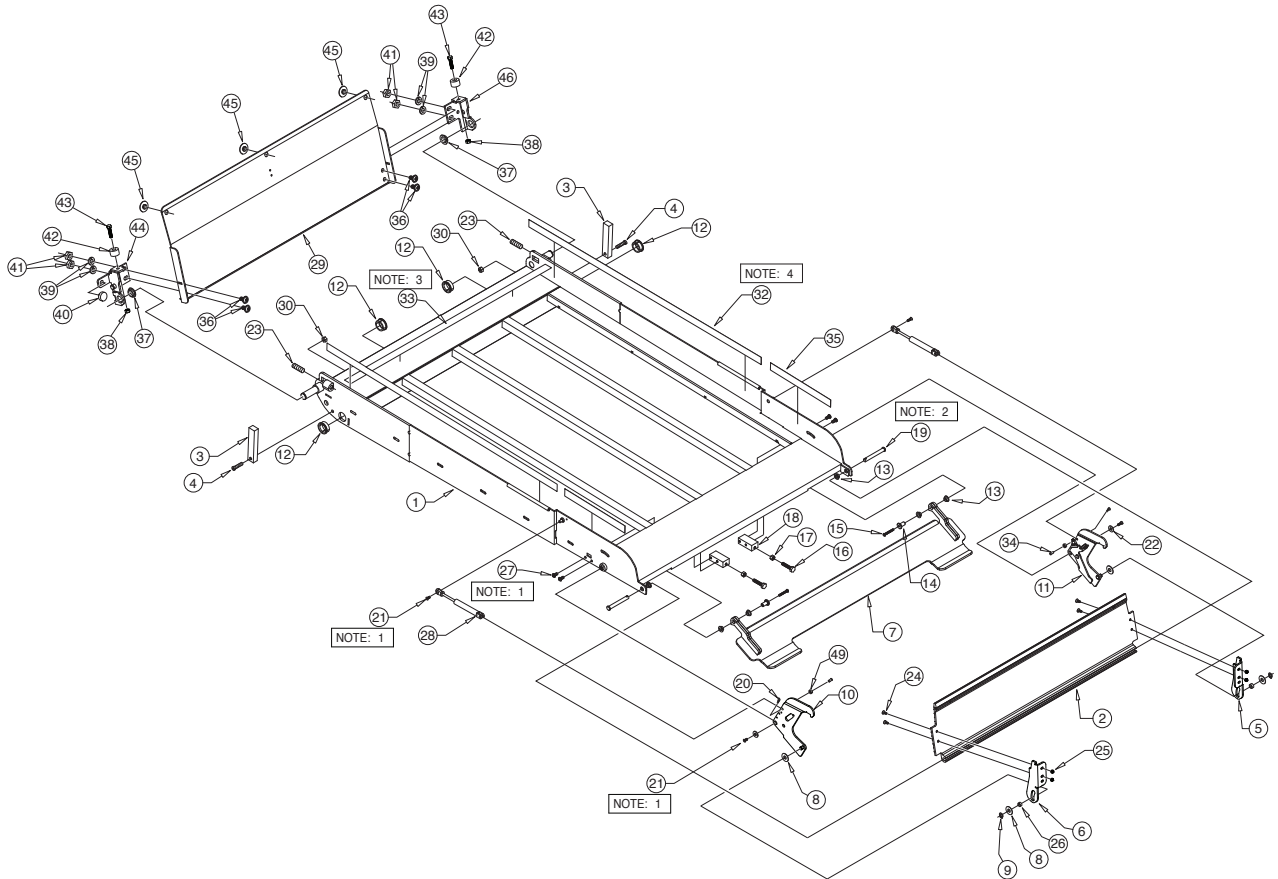

ITEM	QTY.	PART NO.	DESCRIPTION
25	4	10775	NUT-1/4-20 HEX LOCK/AUTO-BK
24	4	40-4230-0	SCREW-1/4-20 X 5/8" FHSC
23	2	18663	SCREW-1/2-20 X 1.5 SET-LOCK/AUTO-BK
22	2	990-0341	ADAPT-CYL/ROLL STOP LEVER-OUT
21	4	24537	SCREW-#10-32X3/8 FL HD-HX SKT/AUTO-BK
20	2	36003	HAIRPIN COTTER-STAINLESS-.042"
19	2	24932BK	PIN-CLEVIS 3/8 X 3" EFF LEN.-W/O HOLE/BK
18	2	33411BM	BRACKET ADJUST-SPLIT FOOT
17	2	10058	NUT-5/16-18 HEX/AUTO-BK
16	2	10013	BOLT-5/16-18 X 1" HEX HD. CAP
15	2	40-1092-0	SCREW-10-32 X 1.25" SHCS
14	2	32759	STANDOFF-FOOT MOUNT
13	6	24028	BEARING-PLASTIC-FLANGE-3/8IDX1/4"
12	4	28031	BEARING-FLANGE-1 X 1/2-16FDU08
11	1	400375ABM	ASSY-ROLL STOP LATCH/OCCUPIED SWITCH-FRONT
10	1	945-4206RNA	ASSY-ROLL STOP LATCH/OCCUPIED SWITCH-REAR
9	2	13889	RING-3/8 RETAINING SNAP
8	4	29371	WASHER-THRUST-.875 OD./50 ID./0585T
7	1	945-0200NW-34BM	ROLL STOP ACTIVATION FOOT
6	1	945-3202RNBM	BKT-LATCH/ROLL STOP/REAR
5	1	945-3202FNBM	BKT-LATCH/ROLL STOP/FRONT
4	2	81003-000	SCREW-5/16-18 X 1 1/4 SHCS BK ZINC
3	2	900-0311BM	STOP-PLATFORM
2	1	945-3312NA34YL	ROLL STOP-ALUM/RUBBER END/ASSY/34"
1	1	400365WBM	PLATFORM-NCL919IB-2 34" X 51"

ITEM	QTY.	PART NO.	DESCRIPTION
49	2	400213	LATCH SPACER
48	3	26362*	RIVET-SNAP BLACK-.201" X .256"/.295"
47	3	84396*	CLAMP-1/4" ID NYLON LOOP BLK
46	1	945-0431FNW	WMT-BKT-BRIDGE PLATE/FR
45	3	916-5406	BEARING-UHMW FLAT-THIN-BLK
44	1	945-0431RNW	WMT-BKT-BRIDGE PLATE/RR
43	2	10001	BOLT-1/4-20 X 1" HEX
42	2	33603	BUMPER-1" X 5/8" LG NAT UHMW/BRIDGEPLATE
41	4	10059BK	NUT-3/8-16 HEX/AUTO-BK
40	1	32408	RUBBER BUMPER-VERT CHAN.
39	4	10069BK	WASHER-3/8" LOCK/AUTO-BK
38	2	14614Z	NUT-1/4-20 NYLOCK/AUTO - ZINC
37	2	24012	BEARING-FLANGE-3/4" X 1/4"-12FDU04
36	4	25171	BOLT-3/8-16 X 3/4" FLBHS-CS-GD8
35	2	30236R011	DECAL-BOUNDARY YELLOW LEXAN 1" X 11"
34	2	401002	PIN-ROLLSTOP GAS SPRING
33	1	30236R032.5	DECAL-BOUNDARY YELLOW LEXAN 1" X 32 1/2"
32	2	30236R035.5	DECAL-BOUNDARY YELLOW LEXAN 1" X 35 1/2"
31	8	91010-000 *	CABLE TIE 3 3/4" BLACK
30	2	28324BK	NUT-5/16-18 TOP LOCK/AUTO-BK
29	1	915-0147NW34YL	WMT-BRIDGE PLATE-PLT-34/48" FTG (945-0147NA34YL INCL 29, 36-46)
28	2	32831	GAS-SPRING-30LB-3.54X9.65
27	4	15733	BOLT-1/4-20 X 1 1/2" BUT HD SOC/AUTO-BK
26	2	945-2336N	BEARING-PLATFORM SLIDE

\* ITEMS NOT SHOWN

# **BraunAbility® Limited Warranty**

## **WARRANTY COVERAGE AND WARRANTY COVERAGE TIME PERIODS**

BraunAbility (“Braun”) warranty covers certain parts of this wheelchair lift for three (3) years or 10,000 cycles and the cost of labor to repair or replace those parts for one (1) year or 3,000 cycles. If The Braun Corporation receives the warranty registration card within 20 days after the lift is put into service, the warranty labor coverage will increase from one (1) year or 3,000 cycles to three (3) years or 10,000 cycles. In addition, providing the warranty registration card is returned as noted above, the following lift’s power train parts are warranted for five (5) years or 15,000 cycles: Cable, Cylinder, Flow Control, Gear Box, Motor, Pump, Hydraulic Hose and Fittings. This limited warranty covers substantial defects in materials and workmanship of the lift, provided that the lift is operated and maintained properly and in conformity with the owner’s manual. The warranty period begins on the date that the product is delivered to the first retail purchaser by an independent, authorized dealer of Braun, or, if the dealer places the product into any type of service prior to retail sale, on the date the dealer first places the product in such service. This limited warranty applies only to the first purchaser. It may not be transferred.

## **WHAT BRAUN WILL DO TO CORRECT PROBLEMS**

In the event that a substantial defect in material or workmanship, attributable to Braun, is found to exist during the first year of warranty coverage, it will be repaired or replaced, at Braun’s option, without charge for parts or labor to the owner, in accordance with the terms, conditions and limitations of this limited warranty. If the substantial defect in material or workmanship, attributable to Braun, is found to exist during the second or third year of warranty coverage, it will be repaired or replaced, at Braun’s option, without charge to the owner for parts, only, in accordance with the terms, conditions and limitations of this limited warranty. Providing the warranty card is returned within 20 days as outlined above, the labor warranty period will be extended by two years of coverage in accordance with the terms, conditions, and limitations of this limited warranty. In addition, if a substantial defect in material or workmanship, attributable to Braun, is found to exist during the fourth or fifth year of warranty coverage to the following lift’s power train parts: Cable, Cylinder, Flow Control, Gear Box, Motor, Pump, Hydraulic Hose and Fittings, it will be repaired or replaced, at Braun’s option, without charge to the owner for parts, only, in accordance with the terms, conditions and limitations of this limited warranty. The cost of labor for repair or replacement at any time after the warranty coverage detailed above is the sole responsibility of the owner.

Braun’s obligation to repair or replace defective materials or workmanship is the sole obligation of Braun under this limited warranty. Braun reserves the right to use new or remanufactured parts of similar quality to complete any work, and to make parts and design changes from time to time without notice to anyone. Braun reserves the right to make changes in the design or material of its products without incurring any obligation to incorporate such changes in any previously manufactured product. Braun makes no warranty as to the future performance of this product, and this limited warranty is not intended to extend to the future performance of the product. In addition, the owner’s obligation to notify Braun, or one of its authorized, independent dealers, of a claimed defect does not modify any obligation placed on the owner to contact Braun directly when attempting to pursue remedies under state or federal law.

## **LIMITATIONS, EXCLUSIONS AND DISCLAIMER OF IMPLIED WARRANTIES**

**ANY IMPLIED WARRANTY THAT IS FOUND TO ARISE BY WAY OF STATE OR FEDERAL LAW, INCLUDING ANY IMPLIED WARRANTY OF MERCHANTABILITY OR ANY IMPLIED WARRANTY OF FITNESS, IS LIMITED IN DURATION TO THE TERMS OF THIS LIMITED WARRANTY AND IS LIMITED IN SCOPE OF COVERAGE TO THE SCOPE OF COVERAGE OF THIS LIMITED WARRANTY.** Braun disclaims any express or implied warranty, including any implied warranty of fitness or merchantability, on items excluded from coverage as set forth in this limited warranty. Braun makes no warranty of any nature beyond that contained in this limited warranty. No one has authority to enlarge, amend or modify this limited warranty, and Braun does not authorize anyone to create any other obligation for it regarding this product. Braun is not responsible for any representation, promise or warranty made by any independent dealer or other person beyond what is expressly stated in this limited warranty. Any selling or servicing dealer is not Braun’s agent, but an independent entity.



## **BraunAbility® Limited Warranty**

**BRAUN SHALL NOT BE LIABLE FOR ANY INCIDENTAL OR CONSEQUENTIAL DAMAGES THAT MAY RESULT FROM BREACH OF THIS LIMITED WARRANTY OR ANY IMPLIED WARRANTY. THIS EXCLUSION OF CONSEQUENTIAL AND INCIDENTAL DAMAGES SHALL BE INDEPENDENT OF ANY FAILURE OF THE ESSENTIAL PURPOSE OF ANY WARRANTY, AND THIS EXCLUSION SHALL SURVIVE ANY DETERMINATION THAT THIS LIMITED WARRANTY OR ANY IMPLIED WARRANTY HAS FAILED OF ITS ESSENTIAL PURPOSE.** This warranty does not cover, and in no event shall Braun be liable for towing charges, travel, lodging, or any other expense incurred due to the loss of use of the product or other reason.

Some states do not allow limitations on how long an implied warranty lasts, or the exclusion or limitation of incidental or consequential damages, so the above limitations or exclusions may not apply to you.

### **HOW TO GET SERVICE**

To obtain warranty service the owner must do all of the following:

1. Notify an authorized service center, of the claimed defect attributable to Braun, within the warranty coverage period designated above
2. Provide the notification mentioned in (1), above, within ten (10) days of when the owner discovered, or should have discovered, the claimed defect
3. Promptly schedule an appointment with and take the product to an authorized service center for service.
4. Pay any transportation costs and all expenses associated with obtaining warranty service.

Since Braun does not control the scheduling of service work at the independent dealerships you may encounter some delay in scheduling or completion of work. If you need assistance you may contact Braun, at 631 West 11th Street, Winamac, Indiana 46996; 1-800-THE-LIFT, (843-5438).

If two (2) or more service attempts have been made to correct any covered defect that you believe impairs the value, use or safety of the product, or if it has taken longer than thirty (30) days for repairs to be completed, you must, to the extent permitted by law, notify Braun directly, in writing, at the above address, of the unsuccessful repair(s) of the alleged defect(s) so that Braun can become directly involved in providing service pursuant to the terms of this limited warranty.

### **WHAT IS NOT COVERED**

This Limited Warranty does not cover any of the following: defects in materials, components or parts of the product not attributable to Braun, any material, component or part of the product that is warranted by another entity (Note: the written warranty provided by the manufacturer of the material, component or part is the direct responsibility of that manufacturer); items that are added or changed after the product leaves Braun's possession; additional items installed at any dealership, or other place of business, or by any other party, other than Braun; normal wear, tear, usage, maintenance, service, periodic adjustments, the effects of condensation or moisture from condensation; mold or any damage caused by mold; imperfections that do not affect the product for its intended purpose; items that are working as designed but that you are unhappy with; problems related to mis-operation, misuse, mishandling, neglect or abuse, including failure to maintain the product in accordance with the owner's manual, or other routine maintenance such as inspections, lubricating, adjustments, tightening of screws, sealing, wheel alignments or rotating tires; damage due to accident or collision, including any acts of weather or damage or corrosion due to the environment; theft, vandalism, fire, or other intervening acts not attributable to Braun; damage resulting from tire wear or tire failure; defacing, scratches, dents or chips on any interior or exterior surface of the product, including those caused by rocks or other road hazards, damage caused by off road use, overloading or alteration of the product, or any of its components or parts.

Defects and/or damage to interior and exterior surfaces and other appearance items may occur at the factory or when the product is in transit. These items are usually detected and corrected at the factory or by

## **BraunAbility® Limited Warranty**

a dealer prior to delivery to the purchaser. You must inspect the product for this type of damage when you take delivery. If you find any such defect or damage you must notify the selling dealer, or Braun, at the time of delivery to have these items covered by this limited warranty and to have work performed on the items at no cost to you as provided by this limited warranty.

### **EVENTS DISCHARGING BRAUN FROM OBLIGATION UNDER WARRANTY**

The following shall completely discharge Braun from any express or implied warranty obligation to repair or replace anything and void this warranty: misuse, neglect, collision, accidents, failure to provide routine maintenance (See Owner's Manual), unauthorized alteration, off road use, Acts of Nature, damage from weather or the environment, theft, vandalism, tampering, fire, explosions, overloading the product and odometer tampering.

### **LEGAL REMEDIES**

Any action to enforce any portion of this limited warranty, or any implied warranty, must be commenced within six (6) months after expiration of the warranty coverage period designated above or the action will be barred because of the passage of time. Any performance of repairs shall not suspend this limitation period from expiring. Any performance of repairs after the warranty coverage period has expired, or performance of repairs regarding any thing excluded from coverage under this limited warranty shall be considered "good will" repairs, and they will not alter the terms of this limited warranty, or extend the warranty coverage period or the filing limitation period in this paragraph. In addition, since it is reasonable to expect that the product will need some service during the warranty period; this warranty does not extend to future performance. It only sets forth what Braun will do and does not guarantee anything about the product for any time period. Nothing in this warranty, or any action of Braun, or any agent of Braun, shall be interpreted as an extension of any warranty period or the filing limitation period in this paragraph. Some states do not allow a reduction in the statute of limitations, so this reduction may not apply to you.

### **WARRANTY REGISTRATION and MISCELLANEOUS**

Your warranty registration records should be completed and delivered to the appropriate companies, including the Braun Delivery Checklist & Warranty form. That form must be returned to Braun within twenty (20) days of purchase. The Braun warranty will not be registered unless this warranty registration is completed and received by Braun. Failure to file this warranty registration with Braun will not affect your rights under this limited warranty as long as you can present proof of purchase, but it can cause delays in obtaining the benefits of this limited warranty, and it changes the start date of the warranty to the date of final assembly of the product by Braun.

Braun agrees to repair or replace any of its factory installed parts found to have substantial defects within the appropriate warranty period designated above, provided that the repair is authorized by Braun and carried out by an authorized service center (a Braun labor schedule determines the cost allowance for repairs). Braun will not honor any warranty claim for repairs or replacement of parts unless the claim is submitted with the appropriate paperwork, and the work is completed by an independent, factory authorized service center. The appropriate paperwork can be obtained by written or phone contact with Braun at the contact information in this warranty.

Braun reserves the right to designate where any warranty work can be performed. Braun also reserves the right to examine any defective workmanship or part prior to giving any authorization for warranty work. Braun's return authorization procedure must be adhered to in order to process any warranty claims.

**THIS WARRANTY GIVES YOU SPECIFIC LEGAL RIGHTS. YOU MAY ALSO HAVE OTHER RIGHTS THAT VARY FROM STATE TO STATE.**



Service Manual

# NCL Century 2

Public Use Wheelchair Lifts

Lift Serial Numbers

**14123000001**

thru

**15041700144**

Patent #5,261,779

Patent #6,599,079

Patent #7,422,408

Patent #6,238,169

Patent #6,692,217

Patent #7,441,995

Patent #6,464,447

Patent #6,739,824

Patent #7,530,226

Patent #7,306,422



631 West 11th Street, P.O. Box 310, Winamac, IN 46996, USA

Phone: 1-574-946-4139 • 1-800-THE-LIFT • [www.braunability.com](http://www.braunability.com)