

Driveline Guard – Missing Brace on A3FE and BBCV Units

Service Notice #18-1109

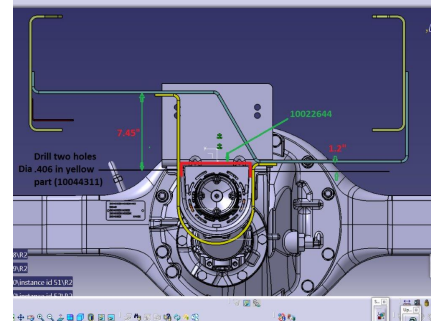
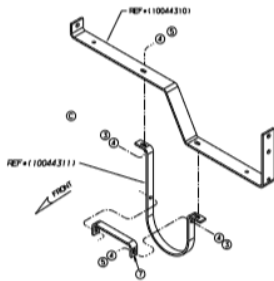

Missing Brace May Cause Driveline to Contact Air Brake Components on A3FE and BBCV Units

We have found that with a specific driveline guard configuration that a cross-brace was left off. Without this brace there is the possibility that the driveline could contact an air tank and air lines should the driveline break free.

The guard in question is shown in Figure #1 and is a “mid-mount” guard which is generally mounted to protect the center section of the driveline near the air tanks as in Figures #2 & #3.

Generally we have found that most units have the holes predrilled in the “loop” for the cross-brace and installing is a matter of bolting the brace (shown in red in Figure #1) and torquing the bolts to 29-33 ft/lbs.

We are asking that customers inspect their units to ensure the bracket is in place, if it is not please contact New York Bus Sales and we will provide the part at N/C.

There is an added photo showing the brace placement in Figure #4 should holes need to be drilled.

ALL of our Service Updates can be found on the [New York Bus Sales website](#)
Or at the [New York Head Mechanic website](#)

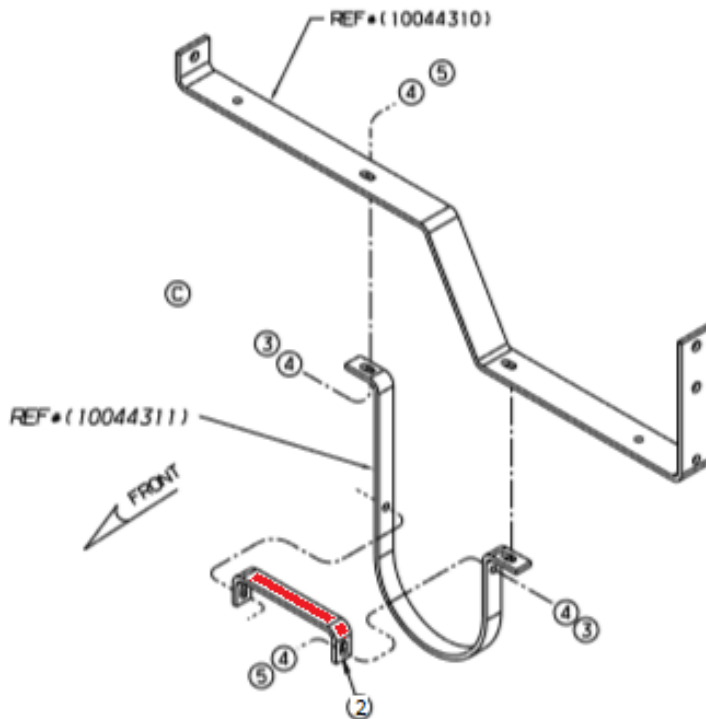

| KEY | P/N | DESCRIPTION | QTY |
|-------|-----------|--|-----|
| (B) 1 | SEE CHART | STRAP, GUARD, DRIVE LINE | 1 |
| 2 | 10022644 | BRACKET, CROSS, DRIVE LINE GUARD STRAP | 1 |
| 3 | 00559195 | CAPSCREW, HEX HD, 3/8-16 X 1, GR8, YEL ZN DICH | 4 |
| 4 | 01107085 | WASHER, FLAT, 13/32X13/16X3/32, HDN, BLKZN | 8 |
| 5 | 00826297 | NUT, HEX HD, .375-16, LOCK, YEL ZNDICH | 4 |
| | | | |
| | | | |

TORQUE ITEM #5 29-33 FT-LBS.

Figure #1

ALL of our Service Updates can be found on the [New York Bus Sales website](#)
Or at the [New York Head Mechanic website](#)



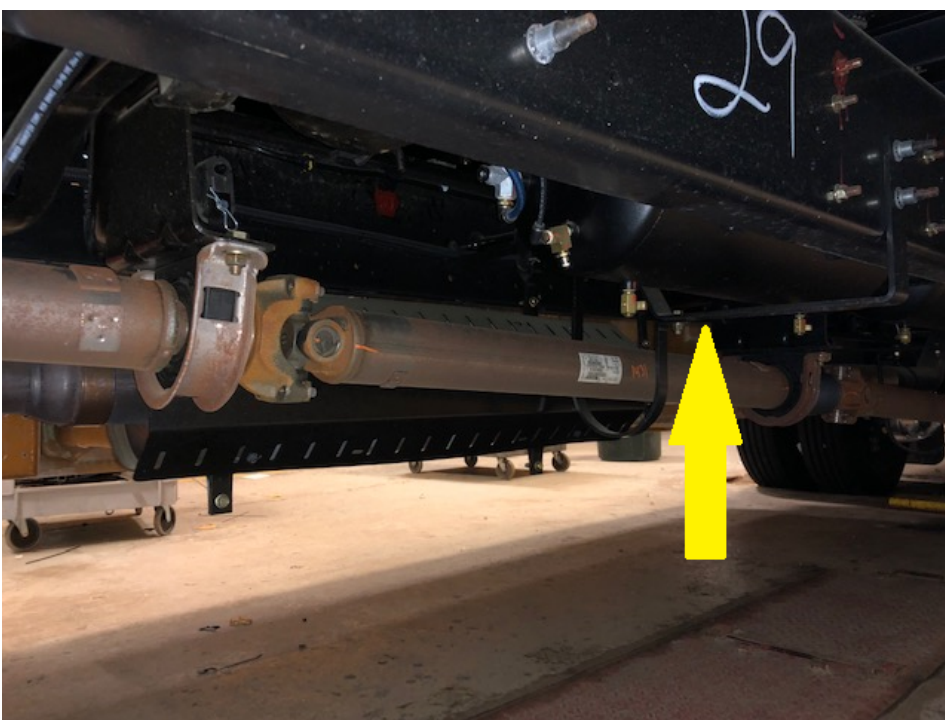

Figure #2



Figure #3

ALL of our Service Updates can be found on the [New York Bus Sales website](#)
Or at the [New York Head Mechanic website](#)

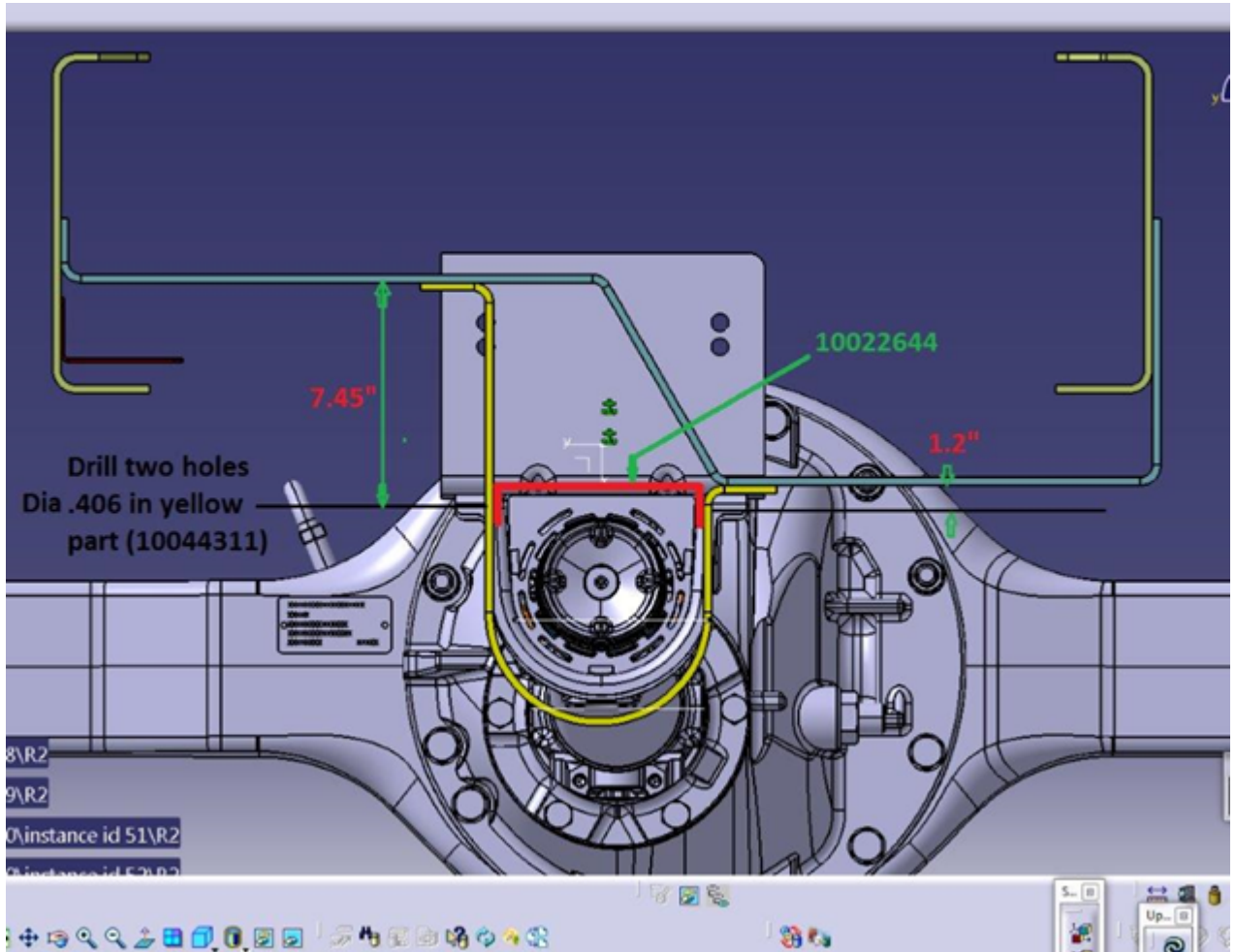

Figure #4

BRACE PART #10022644

ALL of our Service Updates can be found on the [New York Bus Sales website](#)
Or at the [New York Head Mechanic website](#)

CONTACT OUR SERVICE OR PARTS DEPARTMENT WITH ANY QUESTIONS

SERVICE

Chittenango: 800-962-5768

Daryl Wallace or Brian Lamaitis

Rochester: 800-463-3232

Dave Schaub

Albany: 866-867-1100

Ben Reiling

Lower Hudson Valley Region:

845-609-7070

Marc Matwijec

Warranty: 800-962-5768

Morgan Jenkins

Customer Service Representatives

Eastern Region:

Gary Bigness

845-500-3707

Central Region:

Josh Coon

315-263-0765

Western Region:

Mike Panzica

716-908-3186

PARTS

Director of Parts

Jim Hogan

jhogan@newyorkbussales.com

607-227-5794

Chittenango: 800-962-5768

Gari McQuade

gmcquade@newyorkbussales.com

Bill Cox

bcox@newyorkbussales.com

John Lewin

jlewin@newyorkbussales.com

Dave Grant

dgrant@newyorkbussales.com

Albany: 866-867-1100

Sean Conway

sconway@newyorkbussales.com

Pat Murphy

pmurphy@newyorkbussales.com

Rochester: 800-463-3232

Tim Gross

tgross@newyorkbussales.com

Steve Hibbard

shibbard@newyorkbussales.com

ALL of our Service Updates can be found on the [New York Bus Sales website](#)
Or at the [New York Head Mechanic website](#)

