

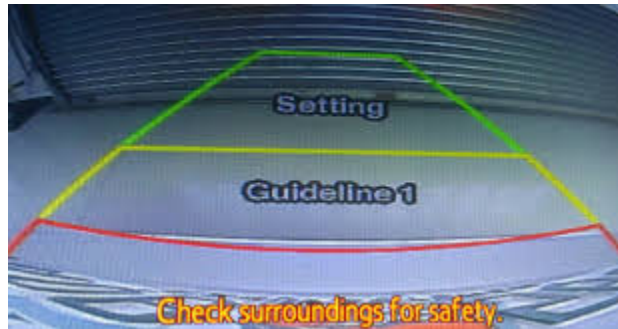

Rosco Back-Up Camera/Mirror Service Update #19-1004



Camera is on ALL the time, not just in reverse!

With the new Rosco back up cameras being installed on units delivered this year, we have been receiving calls that the camera is constantly on, which is not allowed by NYSDOT. Their guideline is that it should only operate when the vehicle is in reverse.

Initially we also thought there was an issue with the system until we did our research and learned that there is a setting called "Steady-On" which always allows the camera to be on. This setting is initiated with the power button on the back of the camera and as drivers position the mirror, we believe they may be accidentally hitting the buttons on the back of the mirror and changing the settings.

Attached is the manual from Rosco on these mirrors and we have circled the specific issue for this on page 5.

ALL of our Service Updates can be found on the [New York Bus Sales website](#)
Or at the [New York Head Mechanic website](#)



MOR-VISION MIRROR MONITOR BACKUP CAMERA SYSTEM

INSTALLATION/USER MANUAL



STSK1030



STSK6630



STSK5530

ALL of our Service Updates can be found on the [New York Bus Sales website](#)
Or at the [New York Head Mechanic website](#)



WARNING

1. To prevent electrical shock, **DO NOT OPEN THE MONITOR CASE**. There are dangerous voltages inside the monitor. There are no user serviceable parts inside.
2. Avoid exposing monitor to water, rain, moisture etc. It is **NOT** waterproof. Any moisture inside the monitor could cause extensive damage.
3. Do not disassemble the camera or the monitor. This voids the warranty. Disassembling the camera will compromise the waterproof seal.

STORAGE

1. Do not expose the monitor to excessive heat or cold. The storage temperature of this device is -5°F~+158° F, and operating temperature is +5°F~+149° F.
2. Do not store or operate in humid environments.

GENERAL

1. This system is intended for use in automotive applications. Power source should be an automobile storage battery (12V/24V).
2. Make sure all cables are connected properly. Improper cable connections may damage the monitor. Remove the cable connection when you do not intend to use the unit for a long period of time
3. Please install this system according to the instructions in this manual.
4. Connect the system to an ignition switched power source. Connection to an unswitched battery source will reduce battery life.



This device complies with Part 15 of the FCC Rules. Operation is subject to the following two conditions:
(1) This device may not cause harmful interference.
(2) This device must accept any interference received, including interference that may cause undesired operation.



WARNING

1. High voltages exist within the monitor. Opening of monitor case is unsafe, and never necessary for operating purposes.
2. In case of any failure, please turn off the display at once, and notify our company or the corresponding dealer. The monitor is made up of many precise electronic components. Any disassembly or modification may lead to damage and voiding of warranty.

COLOR BACKUP CAMERA SYSTEM, COLOR MIRROR MONITOR

Please read this manual thoroughly. This manual contains instructions to make the installation of the camera and monitor easier. The mirror/monitor backup camera system is an upgrade to standard rearview mirror systems, and will provide additional rearview vision when installed and maintained properly. It is not intended in any way to be a substitute for careful and cautious driving. All applicable traffic laws and motor vehicle safety regulations must still be obeyed.

FEATURES

STSC109B CAMERA

- 40,000 pixel image sensor
- 0.5 Lux sensitivity (6 IR-LED)
- Auto white balance (AWB)
- Field of view 150° diagonal
- Automatic electronic iris provides a clearer, more consistent image in low and bright light
- Compact and lightweight design installs easily into most vehicles
- Rain/snow proof

STSM217 HIGH BRIGHTNESS LCD COLOR 7" MONITOR

- Menu button for picture, system and options
- 2 video channels
- Power/stand-by switch
- Built-in speaker
- Auto-dimming

CONTENTS OF COMPLETE SYSTEM

PART LIST	STSK5530
Power Harness	STSK5465/PHAR
Backup Camera	STSK109B
Extension Harness	STSH341
Fuse Holder	HAR6028 (x2)
Interior Mirror/Monitor	STSM530A (includes Monitor STSM217)

PART LIST	STSK6630
Power Harness	STSK5465/PHAR
Backup camera	STSK109B
Extension Harness	STSH341
Fuse Holder	HAR6028 (x2)
Interior Mirror/Monitor	STSM630A (includes Monitor STSM217)

PART LIST	STSK1030
Power Harness	STSK5465/PHAR
Backup Camera	STSC109B
Extension Harness	STSH341
Fuse Holder	HAR6028 (x2)
Interior Mirror/Monitor	STSM1030A (includes Monitor STSM217)

INSTALLATION INSTRUCTIONS

IMPORTANT

For typical rear-view installation, the rear camera **MUST** be connected to the power harness at the connector marked "REVERSE"

NOTE : THE FOLLOWING INSTRUCTIONS ARE FOR TYPICAL REAR-VIEW APPLICATION.

STSC109B CAMERA

1. Find location for camera close to rear marker lights, centered on vehicle. Attachment point must be sturdy enough to support camera and bracket. (Fig. 1)
2. Camera is designed for installation near the top of the vehicle in order to capture images of the rear bumper and danger zones immediately behind the vehicle. It is not recommended to be installed near the bumper. This reduces the view of critical areas and increases the chance of physical damage to the camera.
3. Remove camera cover by removing the screws located at the ends of the camera. Remove camera by twisting retaining ring counterclockwise until camera is released. (Fig. 2)
4. Drill one $\frac{3}{4}$ " (16mm) hole where the camera cable will go through the body of the vehicle. Make sure there are no obstructions behind your hole. (Using the camera base as a template, drill two $\frac{1}{8}$ " (3.5mm) holes for attachment screws. (Fig. 3)
5. Attach camera housing to vehicle with screws provided.
6. Insert camera back into housing and adjust lens angle to desired setting. Note that the light sensor is the bottom of the camera. Once the angle is set, tighten retaining ring onto camera. Tighten set screws on the sides of the camera. (Fig. 4)
7. Return top cover and secure with original screws. (Fig. 5)

STSM217 MONITOR

1. Attach mirror/monitor inside vehicle in an existing interior mirror location (e.g. center of dash, or overhead).
3. Fasten mirror monitor to bracket and adjust mounting angle to allow optimum driver viewing comfort.

STSH341 CAMERA EXTENSION CABLE

1. Be sure to position the cable properly. The male end attaches to the camera. The female end attaches to the power/video/audio distribution harness, typically located under the dashboard.
2. Do not run the cable over sharp edges or corners. Do not kink the cable. Keep the cable away from hot and rotating parts.
3. Fasten all cable runs, and secure all excess cable. (Fig. 6)

WIRING CAMERA AND MONITOR

1. Monitor: Connect the red wire to an ignition switched accessory (ex: radio) power source, and connect the black wire to chassis ground. See wiring diagram for connections (See Fig. 6.)
2. The monitor terminates in a 13-pin connector, which should be connected to the mating 13-pin receptacle end of the power/video/audio distribution harness. When connecting the cables check to make sure to match the directions of the arrows on the 13-pin connectors (male to female.)
3. For typical rearview installation, connect the camera extension cable from the rear view camera to the harness connector marked C1.
4. For multi-camera installations, be sure to mark each extension cable properly and connect to the appropriate harness connector marked C1 or C2. Bundle excess cable together using a cable tie or electrical tape.
5. The green wire is the REVERSE trigger wire. In typical rearview installations, connecting this wire to the vehicle's backup light circuit will activate the rearview image whenever the vehicle shifts into reverse.
6. Camera: Drill a 3/4" (16mm) diameter hole into vehicle body near the camera and bracket. Insert camera cable into vehicle (be careful not to kink cable) and fit grommet into hole. Apply sealant around grommet to increase resistance to water penetration. Connect camera to the camera extension cable which runs inside the vehicle.
7. Feed as much cable as possible into vehicle and clamp securely. This reduces the possibility of it being hooked or snagged.
8. Keep all cables away from HOT, ROTATING, and ELECTRICALLY NOISE components.
9. FUEL TANKERS & OTHER SPECIALTY VEHICLES: All electrical equipment fitted to petroleum vehicles must be connected via battery master switch and must be isolated from the battery while the vehicle is loading and unloading. For other specialty vehicles, please check applicable code and regulations prior to installation.
10. Always consult your dealer when fitting an electrical or electronic equipment to a vehicle fitted with a CAN-bus or multiplex system.

IMPORTANT

For installations requiring multiple cameras, or for installations not requiring typical rearview images, please refer to the wiring diagram (Fig.6) and the particular vehicle's electrical schematic for selection of proper power and trigger connection points.

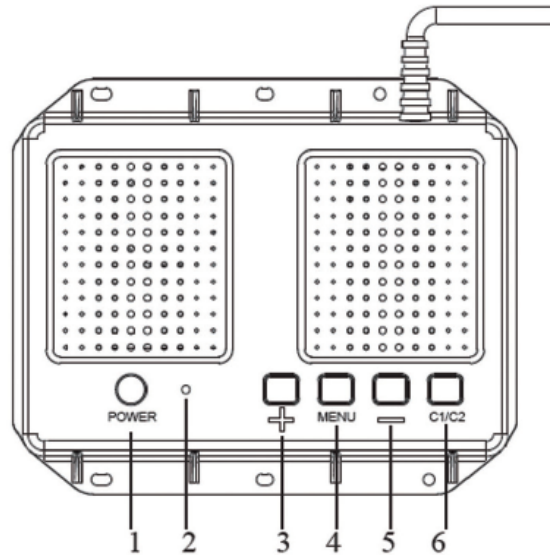

FUNCTIONS AND OPERATIONS

MONITOR

1. POWER

When the ignition is switched on, the monitor will be in standby mode, waiting for trigger signal. (When a trigger wire is energized by 12v power, the image captured by the selected camera will appear on the monitor.) Pressing the power switch will change the monitor status from standby to steady-on. Steady-on mode status will show camera view depending on user selection.

2. LIGHT SENSOR

When auto dimming is active, monitor will automatically change screen brightness according to ambient light around the monitor.

3/5. VOLUME +/-

Adjust Speaker Volume. These buttons are also used to adjust the values within selected setting of menu option.

4. 'MENU' Button (See p.7)

Press MENU to active screen options.
Press Menu to cycle through choices and +/- to change settings.

6. C1/C2

Switches from Camera 1 to Camera 2 and vice-versa.

MENU CONFIGURATION

NOTE: On-screen menu commands should only be selected when monitor is in steady-on mode. Never change settings while operating vehicle.

Press the MENU button once to set desired brightness.
Press +/- to increase/reduce the brightness.
Wait 3 seconds to exit setup mode.

Press the MENU button twice to set desired contrast.
Press +/- to increase/reduce the contrast.
Wait 3 seconds to exit setup mode.

Press the MENU button three times to set desired color.
Press +/- to increase/reduce the color.
Wait 3 seconds to exit setup mode.

Continue to press the MENU button to change desired settings.

Tint: Press +/- to increase/reduce the tint

Language: Press +/- to select English/ French/ Spanish.

Reset: Press +/- to restore factory defaults.

CAM1: Press +/- to select Normal/Mirror mode.

CAM2: Press +/- to select Normal/Mirror mode.

Vertical: Press +/- to flip image vertically.

Dimming: Press +/- to select Auto/ Day/ Night.

Scale: Press +/- to select On/Off for backup grid to appear when in triggered mode.

Scale Adjustment: Press - to change selected line on backup grid.
Press + to adjust position of line on backup grid.

Wait 3 seconds to exit setup mode.

SPECIFICATIONS

STSC109B CAMERA

Pickup Device	1/4" CMOS Sensor
TV System	NTSC
Pixels	720(H) x 480(V) NTSC
Sensing Area	5.6mm x 5.6mm
Horizontal Resolution	420 TV Lines
Signal to Noise Ratio	Minimum 45dB
Power Supply	12VDC
Max Power Consumption	1.8W at 12VDC
Current	MAX. 75MmA
Lens Angle	150° (D)
Operation Temperature	-5°F to +140°F (-20°C to 60°C)
Storage Temperature	-5°F to +167°F (-20°C to 75°C)
Weight	0.23lbs (0.1kg)
Dimensions	W x H x D (83.5 x 57.8 x 44.2 mm) (83.5 x 57.8 x 44.2 mm)

STSM217 MONITOR

Screen	7.0 inch Color TFT-LCD High Brightness
Voltage Input Range	12 to 24 VDC
Power	MAX. 75MmA
Max Current Consumption	850 mA at 12VDC
TV System	NTSC
Video Input/Output	Composite Video Single (1vp-p 750OHM)
Resolution	800(H) x 480(V)
LCD Brightness	1800cd/m2
Operating Temperature	-5°F to +149°F (-15°C to 65°C)
Storage Temperature	5°F to 158°F (-20°C to 70°C)

DISCLAIMER

The use of Rosco's Vehicle CCTV system should not in any way be used as a substitute for careful and cautious driving. Always obey traffic laws and motor safety regulations must always be adhered to. Specifications subject to change without any notice.

FIG. 1

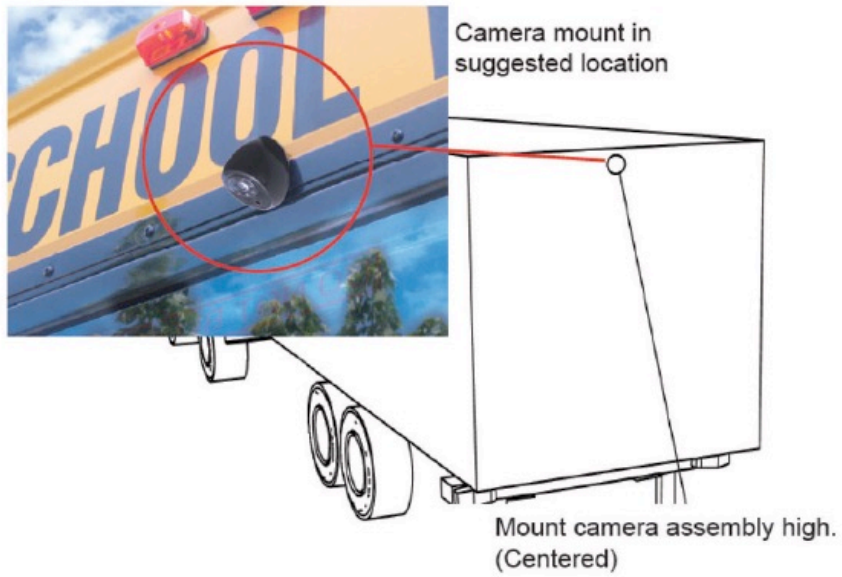

FIG. 2

CAMERA HOUSING

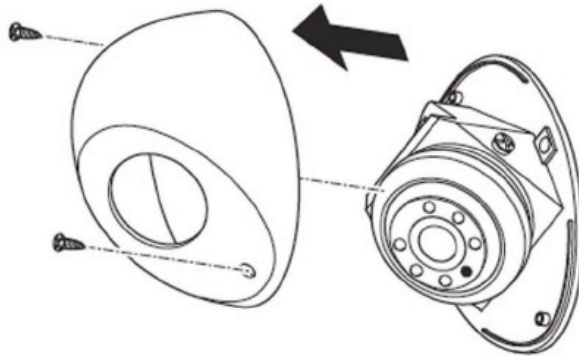
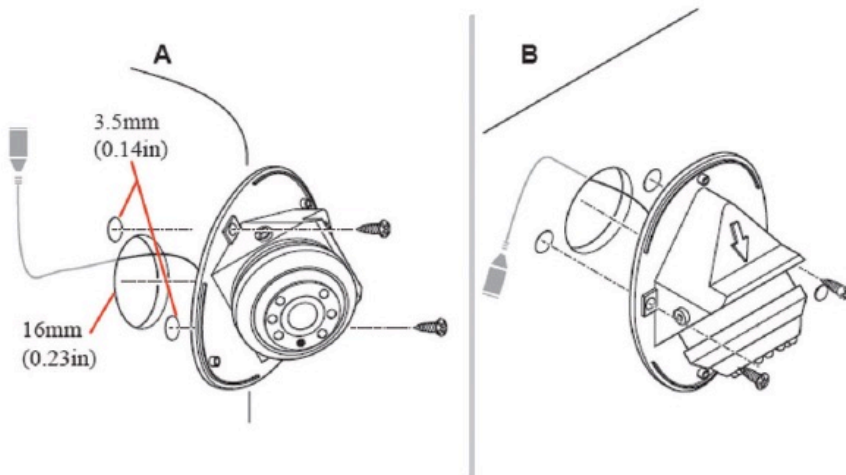

FIG. 3

CAMERA MOUNTING HOLE PATTERN



ALL of our Service Updates can be found on the [New York Bus Sales website](#)
Or at the [New York Head Mechanic website](#)

FIG. 4

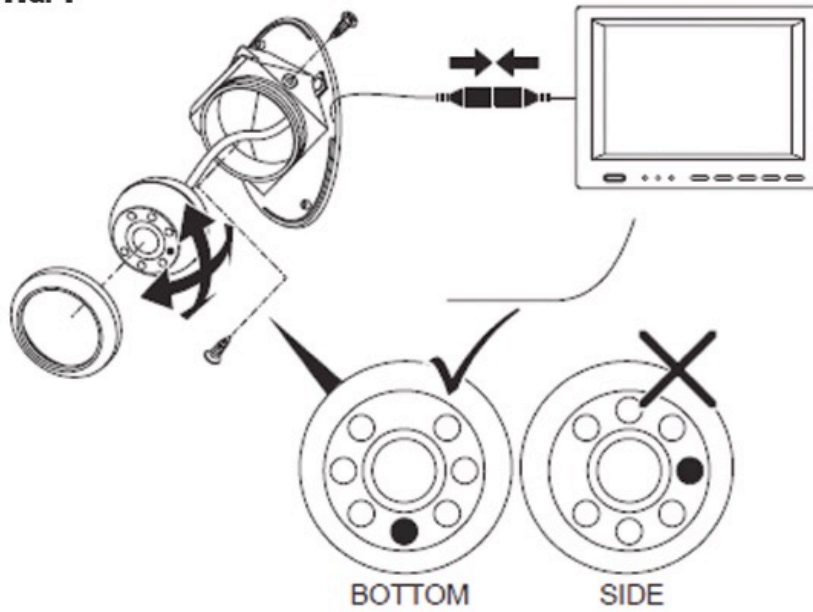

FIG. 5

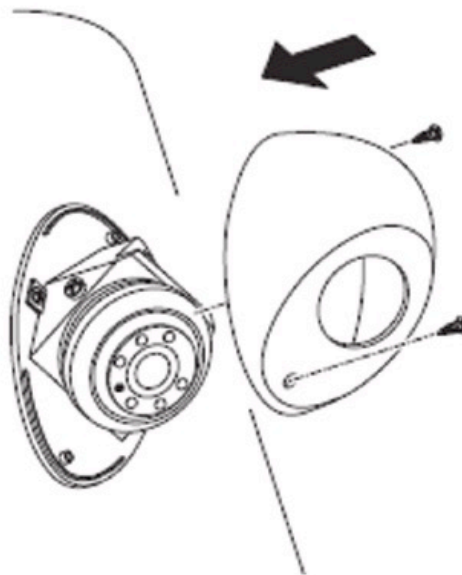
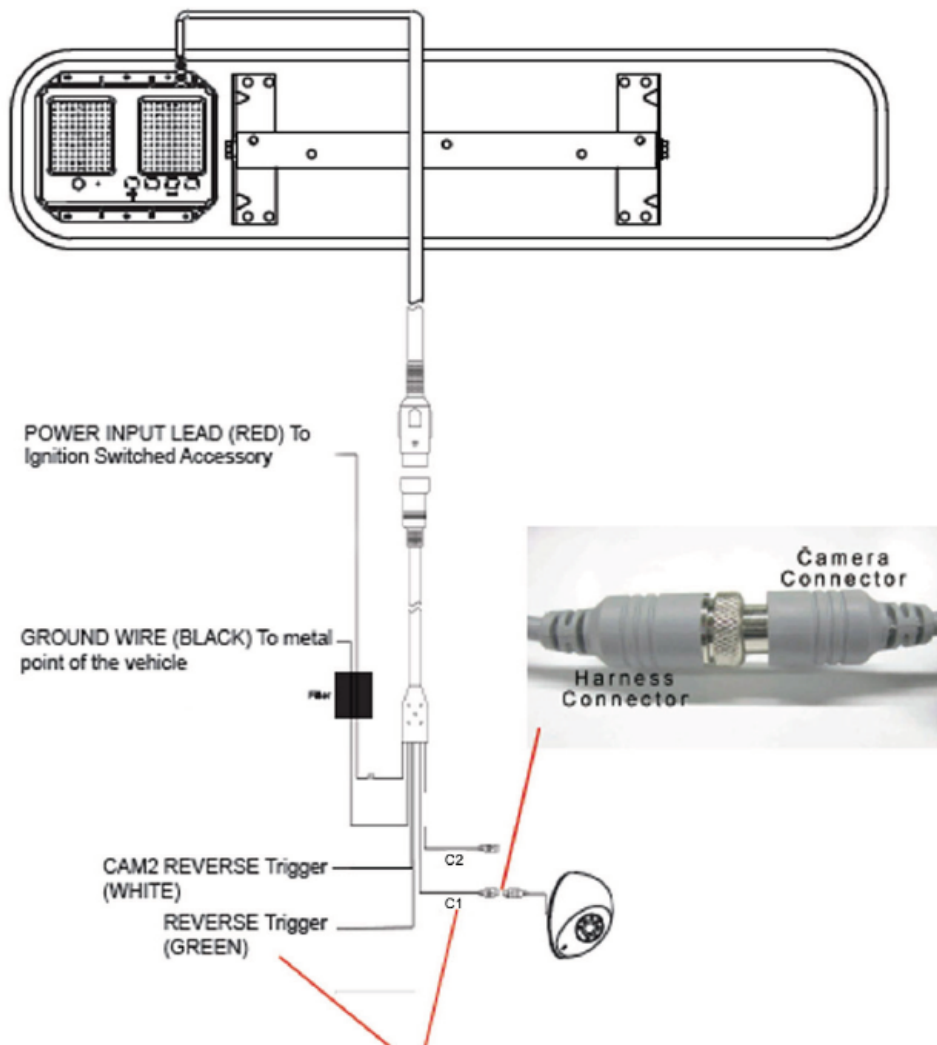

FIG. 6



Note: For typical single camera installation, this trigger wire should be connected to the vehicle's "back up lights" circuit, and the rearview camera should be attached to the connector marked "REVERSE"



A CENTURY OF AUTOMOTIVE VISION SAFETY

90-21 144th Place, Jamaica, New York 11435
TEL (800) 227-2095 • FAX (718) 297-0323
Info@Roscomirrors.com
www.roscomirrors.com www.roscovision.com

M6212018

ALL of our Service Updates can be found on the [New York Bus Sales website](#)
Or at the [New York Head Mechanic website](#)



CONTACT OUR SERVICE OR PARTS DEPARTMENT WITH ANY QUESTIONS

SERVICE

Chittenango: 800-962-5768
Daryl Wallace

Rochester: 800-463-3232
Eric Bosley

Albany: 866-867-1100
Ben Reiling

Lower Hudson Valley Region:
845-609-7070

Customer Support Representatives

Eastern Region:
Gary Bigness
845-500-3707

Central Region:
Call Service
TBD

Western Region:
Call Service
TBD

PARTS

Director of Parts
Jim Hogan
jhogan@newyorkbussales.com
607-227-5794

Chittenango: 800-962-5768

Gari McQuade
gmcquade@newyorkbussales.com

Bill Cox
bcox@newyorkbussales.com

John Lewin
jlewin@newyorkbussales.com

Dave Grant
dgrant@newyorkbussales.com

Albany: 866-867-1100

Sean Conway
sconway@newyorkbussales.com
Dan Haight
dhaight@newyorkbussales.com

Rochester: 800-463-3232

Steve Hibbard
shibbard@newyorkbussales.com
James Roeser
jroeser@newyorkbussales.com

ALL of our Service Updates can be found on the [New York Bus Sales website](#)
Or at the [New York Head Mechanic website](#)

