

Blue Bird Body Hold-Down Maintenance

Service Update #20-0105

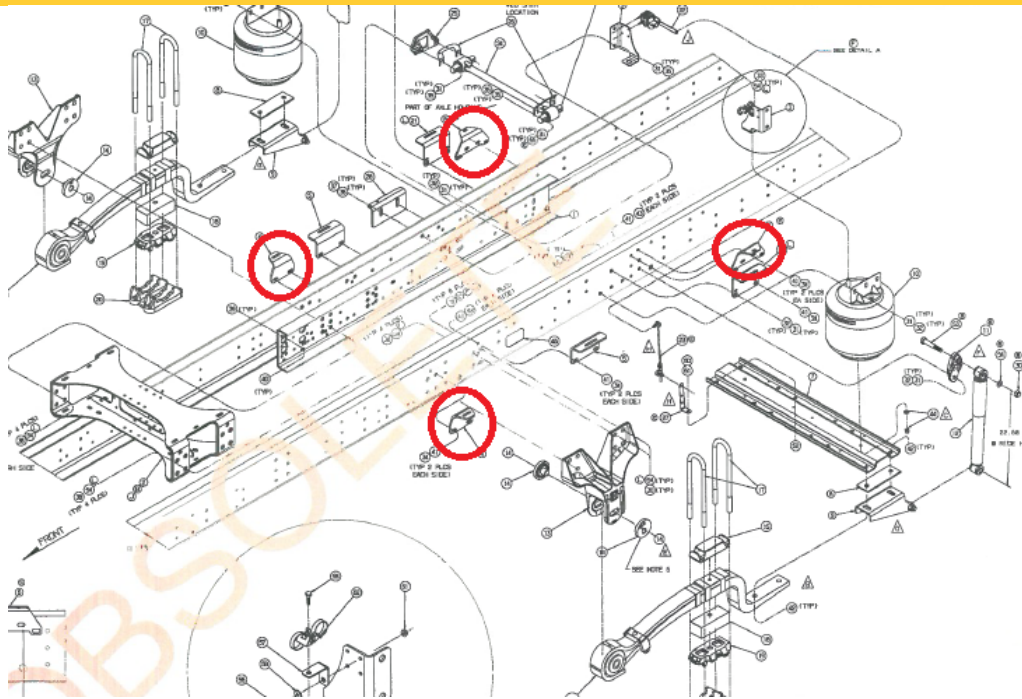

Body Hold-Downs Require Maintenance

Body hold-downs just ahead and behind the rear axle were changed a while ago from a single bolt holding them to the body crossmember to a 2 bolt system (Parts Update #16-05). Please note that these do still require maintenance in the form of re-torquing due to body and frame flex.

The excerpt from the Blue Bird service manual can be found on the next page with details on how often and what the torque should be set to.

ALL of our Service Updates can be found on the [New York Bus Sales website](#)
Or at the [New York Head Mechanic website](#)

Body Tie-down Clamps and Angles

At most places where a joint between two adjacent body floor sections crosses the main frame rails, body tie-down clamps secure the body to the main frame rails. The clamps bolt to the floor joint body bar angles and, when tightened, clamp against the inboard edge of the frame rail's upper flange.

Wherever equipment mounted between the main frame rails prevents the use of a body tie-down clamp (for example, in the area of the rear mounted fuel tank), body tie-down angles are bolted to the outboard side of the frame rail and to the floor joint body bars.

Inspection/Adjustment

All body tie-down clamps and angles should be checked for proper tightness after the first 1000 miles of operation and every three months thereafter. Tighten to 37–41 ft. lbs. (50–56 Nm).

ALL of our Service Updates can be found on the [New York Bus Sales website](#)
Or at the [New York Head Mechanic website](#)



CONTACT OUR SERVICE OR PARTS DEPARTMENT WITH ANY QUESTIONS

SERVICE

Chittenango: 800-962-5768

Daryl Wallace

Rochester: 800-463-3232

Eric Bosley

Albany: 866-867-1100

Ben Reiling

Lower Hudson Valley Region:

845-609-7070

**Customer Support
Representatives**

Eastern Region:

Gary Bigness

845-500-3707

Central Region:

Call Service

TBD

Western Region:

Call Service

TBD

Comments or Concerns:

John Johnston

jjohnston@newyorkbussales.com

Cell 315-263-0766

PARTS

Director of Parts

Jim Hogan

jhogan@newyorkbussales.com

607-227-5794

Chittenango: 800-962-5768

Gari McQuade

gmcquade@newyorkbussales.com

Bill Cox

bcox@newyorkbussales.com

John Lewin

jlewin@newyorkbussales.com

Dave Grant

dgrant@newyorkbussales.com

Albany: 866-867-1100

Sean Conway

sconway@newyorkbussales.com

Dan Haight

dhaight@newyorkbussales.com

Rochester: 800-463-3232

Steve Hibbard

shibbard@newyorkbussales.com

James Roeser

jroeser@newyorkbussales.com

ALL of our Service Updates can be found on the [New York Bus Sales website](#)
Or at the [New York Head Mechanic website](#)

